

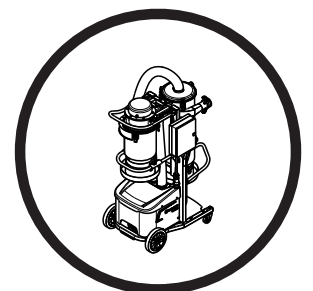

**Workshop manual**  
**DC 6000**



115 63 33-26

# LEGEND

Clicking the title will bring you to the beginning of that chapter.

Clicking the blue links will bring you to that section of the manual

11.2

**ELECTRIC**

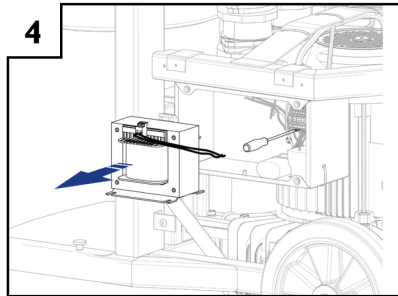
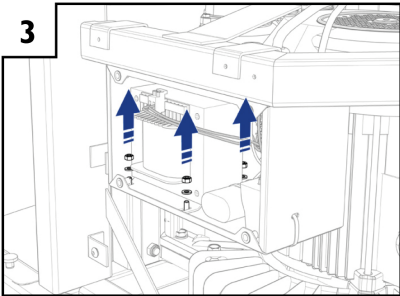
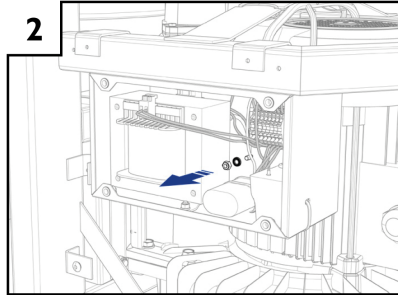
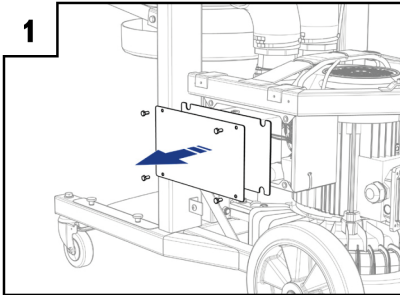

## Replace Transformer

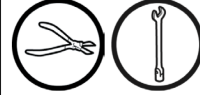

First see [Removing the Side Covers \(p. 34\)](#), [Removing the Battery \(p. 18\)](#) and [Removing the Gear Box \(p. 52\)](#).

1. Remove lid and seal with four screws.
2. Remove ground cable with nut and washer.
3. Remove the three locking nuts and washers.
4. Remove the two cables from the Terminal Blocks using a flat crewdriver. Then lift the transformer out.

Reverse steps for assembly.

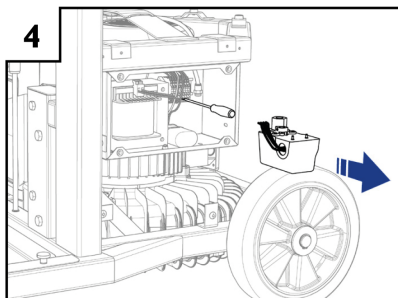
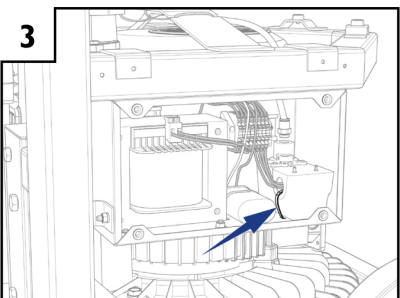
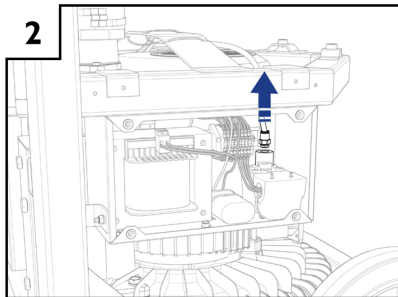
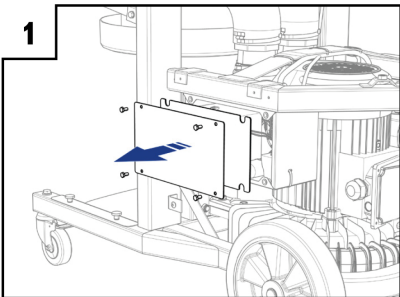

## Remove Pressure Switch

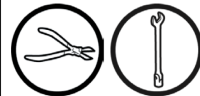

First see [Removing the Side Covers \(p. 34\)](#), [Removing the Battery \(p. 18\)](#) and [Removing the Gear Box \(p. 52\)](#).

1. Remove lid and seal with four screws.
  2. Remove the connector.
  3. Cut the strap.
- Remove the switch.

Reverse steps for assembly.

Alt + Left arrow = Back  
Ctrl + L = Fullscreen

Clicking a tool icon will bring you to the Tools section.

**3. Literature**

Workshop Manual .....	5
Spare Parts Catalog .....	5

**4. Safety Instructions**

General .....	6
Machine Stop Button.....	7

**5. Specification**

Technical Data.....	8
---------------------	---

**6. Tools and Special Tools**

Tools .....	9
-------------	---

**7. Components - Navigation**

DC 6000 .....	10
Electrical box.....	11
Electrical box Lower .....	12

**8. Function Test**

Function Test.....	13
Electrical Functions.....	14
Simplified Electrical Schematic .....	15
Blower Motor .....	16
Blower Motor Electrical Schematic.....	17
Auxiliary Power Outlet.....	18
Auxiliary Power Outlet Electrical Schematic.....	19
PLC.....	20
PLC Electrical Schematic.....	21
Transformer 230V .....	22
Transformer 230V Electrical Schematic .....	23
Purge Function.....	24
Purge Function Electrical Schematic .....	25
Hour Meter.....	26
Hour Meter Electrical Schematic .....	27

**9. Troubleshooting**

Troubleshooting .....	28
-----------------------	----

**10. Service and Maintenance**

Service .....	29
Filter Maintenance.....	30

## 11. Repair Instructions

### 11.1. Covers

Removing the Front Cover.....	32
-------------------------------	----

### 11.2. Electric

Replacing the Main Cable.....	33
Removing Terminal Block X1.....	33
Removing Terminal Block X2.....	34
Removing Contact Blocks H1, H2, S1, S2, S3, S4, S7.....	34
Removing Fuse F3.....	34
Removing Fuse F3.....	35
Removing Relay K4.....	35
Removing Phase Sequencing Relay K3.....	35
Removing Overload Protection Q2.....	35
Removing PLC CR2.....	36
Removing Contactors K1, K2, Q1.....	36
Replace Transformer.....	37
Remove Pressure Switch.....	37

### 11.3. Motor

Remove Air Hose.....	38
Removing Generator.....	39
Removing Motor.....	40

### 11.4. Filter

Replace Filter Valve.....	41
Replace Filter Sealing.....	42

### 11.5. Electrical Drawings

Controls CE.....	43
Controls US.....	44
Power CE.....	45
Power US.....	46

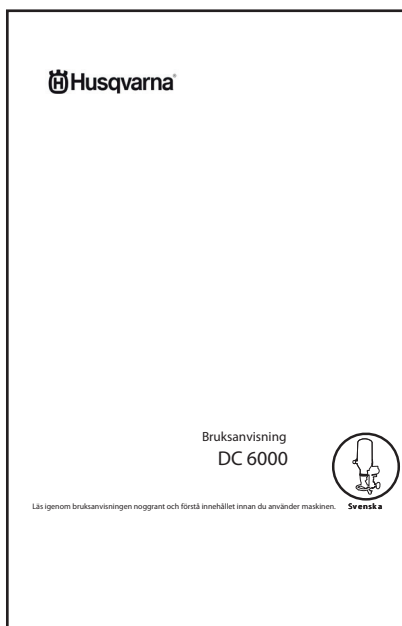

### 3. LITERATURE

#### Workshop Manual

The workshop manual covers all workshop maintenance for the DC 6000. Some very simple and obvious repair work has been omitted.

The manual is divided into numbered chapters as well as chapter headings that are specified in bold at the top of each page .

The table of contents at the beginning of the manual also has a page reference to the beginning of each chapter.



#### Spare Parts Catalog

These catalogs include all the spares for Husqvarna DC 6000.

The catalogs contain complete exploded drawings for each product and the location, spare part number, and appearance of each component is easy to identify.

Link to EPC  
<http://parts.husqvarna.com>

## 4. SAFETY INSTRUCTIONS

### General

- No one may repair the DC 6000 unless they have read and understood the contents of this workshop manual.
- This workshop manual is written for personnel with general knowledge about the repair and service of DC 6000.
- The workshop where the DC 6000 is to be repaired must be equipped with safety equipment in accordance with local bylaws.
- The machine is tested and approved only with equipment originally provided or recommended by the manufacturer.
- It is the responsibility of the user of this workshop manual to ensure that the service and repairs are carried out according to legal requirements to protect the health and safety of the personnel undertaking the work.
- Always read the warning label on the packaging for Loctite and oil, and act according to its instructions.
- Always stop the DC 6000 before carrying out any service or repairs.
- When using compressed air, do not direct the jet towards the body. Air can penetrate into the blood circulation system, which could be fatal.
- Observe local waste regulations.
- Electric shock could cause injury. Do not touch the wires while the DC 6000 is on or plugged in.
- Always make sure all nuts and bolts are correctly tightened.
- Wear personal protective equipment.
- Never carry the machine by holding the cable and never pull the plug by pulling the cable.
- Check that the cables are intact and in good condition. Use cables intended for outdoor use.
- Never use the machine if any cable is damaged.

### Warning and Information



---

The warning box indicates there is a risk of personal injury if the instructions are not followed.

---



---

The information box provides instructions for the reader.

---

### ESD general notice

All electrical devices are sensitive to ElectroStatic Discharges (ESD). A person may carry thousands of volts from being charged sitting in a car seat, wearing shoes with synthetic soles or a synthetic jacket. All discharges one can feel is certain to destroy electronic components. Even those discharges one can't feel may still damage or destroy electronic components. When working with electronic components in our products, always use proper ESD protection!.



### HIGH VOLTAGE

Risk of electric shock. Service work on the machine should be performed with the power cable disconnected.

## Machine Stop Button

The DC 6000 is equipped with a machine stop button which will quickly shut down power to the DC 6000. Note that the electrical cabinet will still be energized even when the machine stop button is pushed.

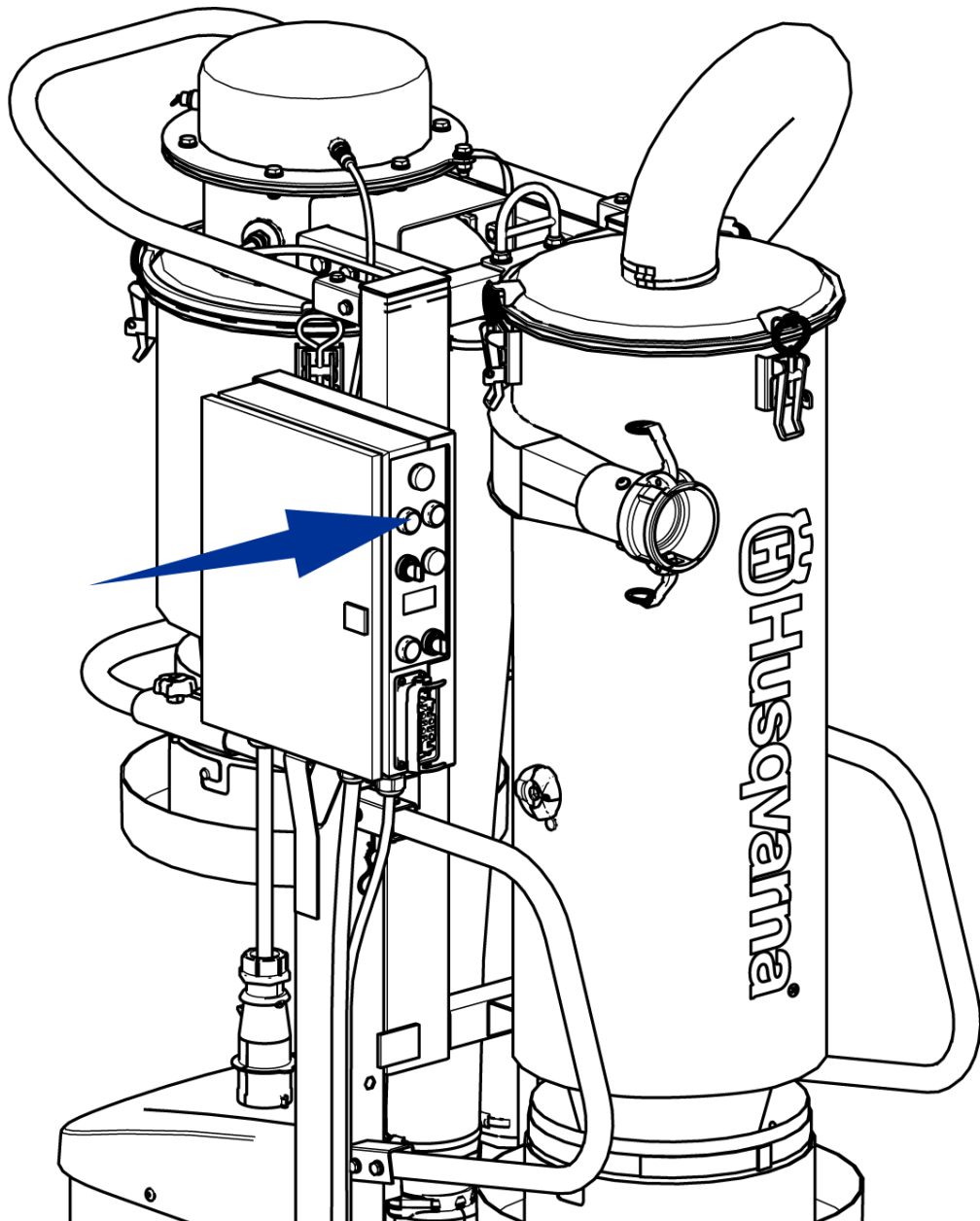

## 5. SPECIFICATION

## Technical Data

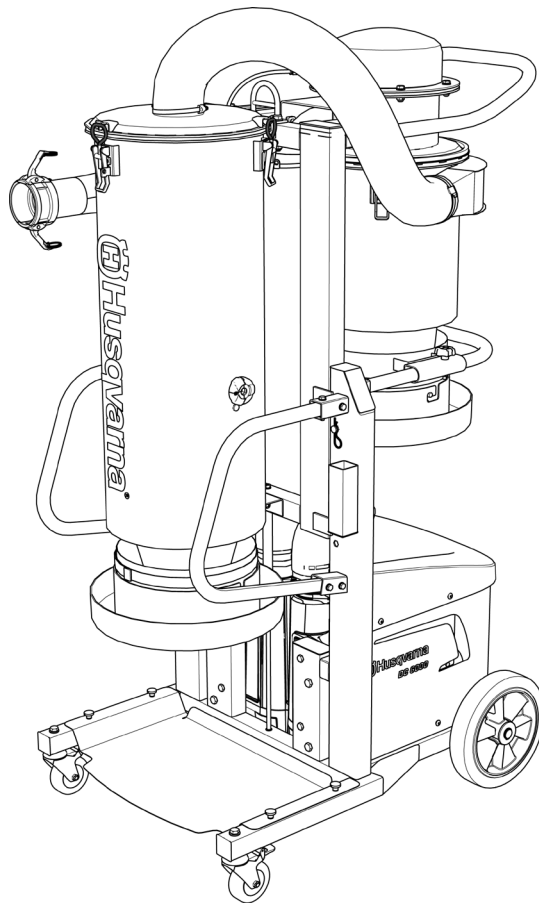







DC 6000	Data
Power, kW	7,75
Rated voltage, V	480/400
Rated current, A	15,9
Power supply	3 phase
Airflow, cfm/l/s	406
Max. vacuum, bar/psi	0,42/3,05
Suction inlet diameter mm/inch	75/3
Total filter area, m2	7.8/84
Weight, kg/lbs	290/639
Size, (LxWxH), mm/inch	1252*766*1899/49*30*75
Lowered	1252*766*1620/49*30*64
<b>Noise emissions (see note 1)</b>	
Sound power level, measured dB(A)	93
Sound power level, guaranteed LWA dB(A)	93
<b>Sound levels (see note 2)</b>	
Sound pressure level at the operators ear, dB(A)	77



**6. TOOLS AND SPECIAL TOOLS**

In the list below you will find the tools and the special tools used in this workshop manual.

**Tools**

<b>Tool</b>	<b>Tool no.</b>	<b>Description</b>
		Ratchet Wrench
		Wrench
		Socket
		Allen Key, Kit 2.5 - 10 mm
		Universal Pliers
		Pliers
		Screwdriver

## 7. COMPONENTS - NAVIGATION

DC 6000

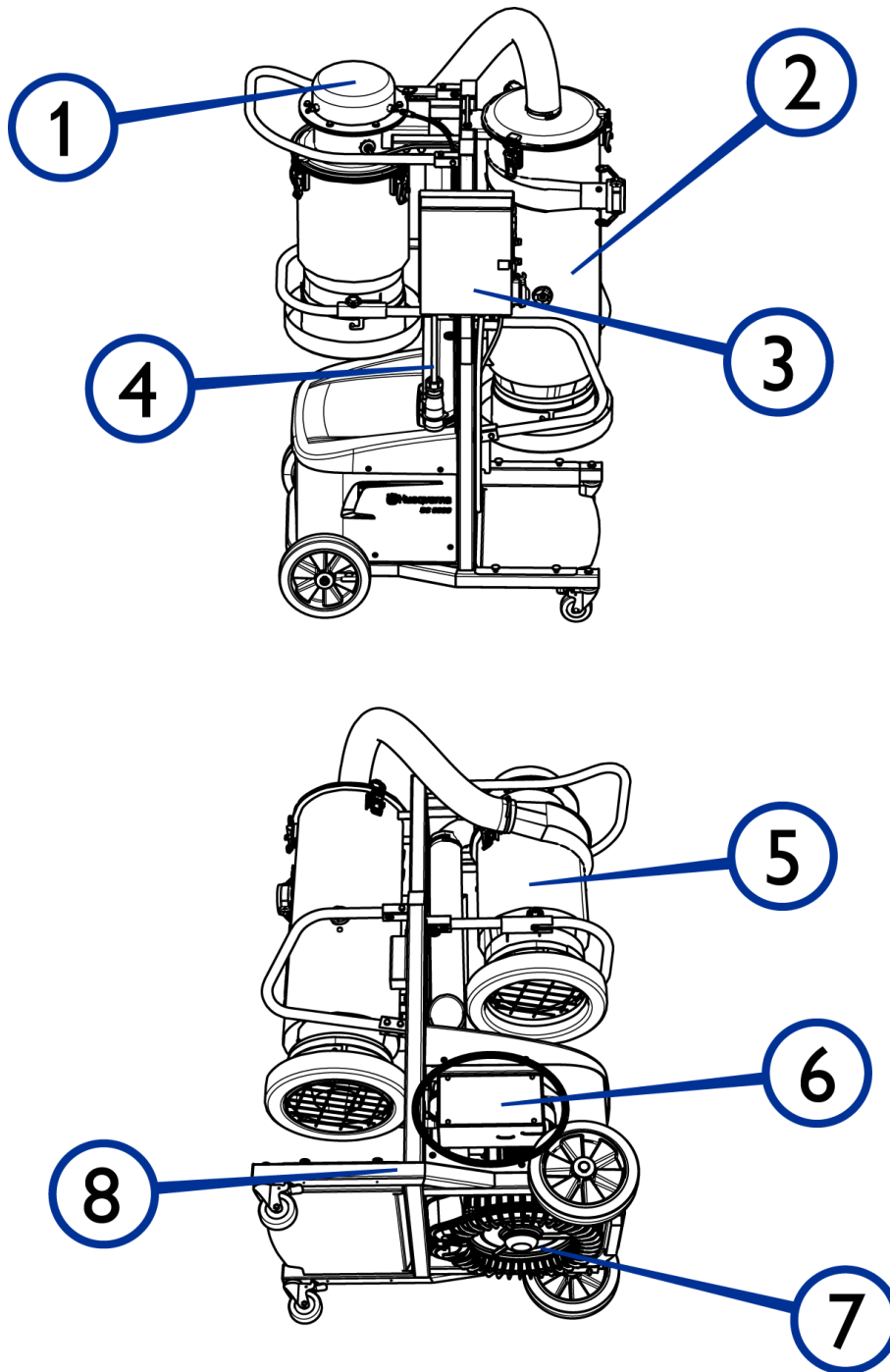

1. Pressure Chamber
2. Cyclone container
3. Electrical Cabinet
4. Power Cable
5. Filter Holder

6. Lower electrical enclosure
7. Blower Motor
8. Frame

## Electrical box

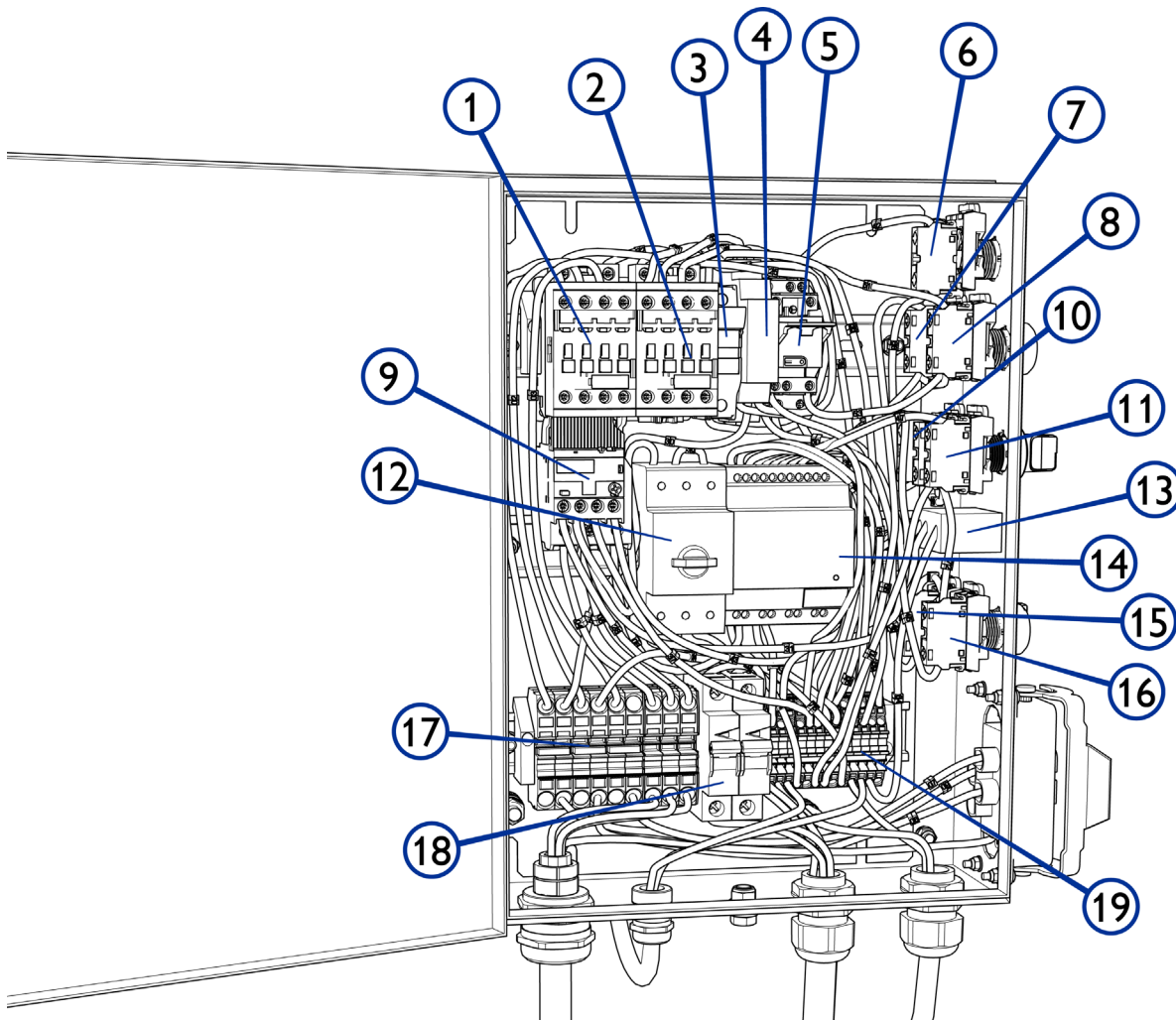

- 1. Contactor, K1
- 2. Contactor, K2
- 3. Fuse holder, F1, Fuse F1
- 4. Phase sequence relay, K3
- 5. Relay, K4
- 6. Pilot light clear, H2
- 7. Pushbutton green, S1
- 8. Pushbutton red, S2
- 9. Overload protection, Q1
- 10. Pilot light red, H1
- 11. Selector switch, S4

- 12. Overload protection, Q2
- 13. Hour meter, CR1
- 14. PLC, CR2
- 15. Pushbutton white, S7
- 16. Selector switch, S3
- 17. Power inlet, X1
- 18. Circuit breaker, F3
- 19. Power outlet, X2

# 7 COMPONENTS - NAVIGATION

## Electrical box Lower

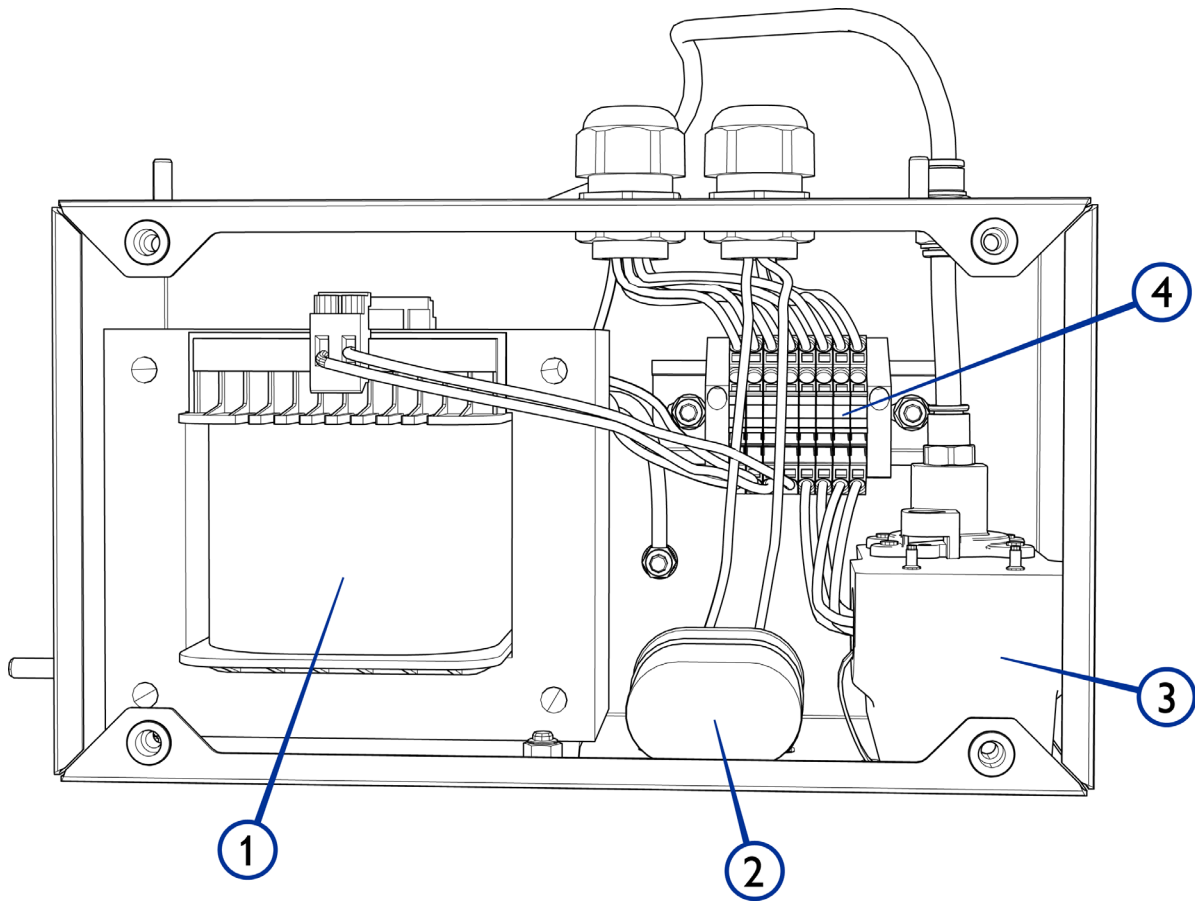

1. Transformer, T1

2. Compressor capacitor, C1

3. Pressure switch, S10

4. Valve connector, X3

---

## **8. FUNCTION TEST**

### **Function Test**

- Connect the Vacuum to a power outlet.
- Push the green button. A white lamp is lit up, and the compressor will start to build up pressure. It can take around 30 seconds until the compressor has reached the correct pressure. (Note: if the correct pressure is maintained the compressor won't engage)
- Put the Purge Setting button in Manual mode, and push the manual purge button.
- The purge should now clean the filter and the compressor should start to build pressure again until the correct pressure is reached. If this doesn't happen see the Purge Fault Tracing section.
- The machine has power and is in stand-by mode.
- Turn the switch to the ON position and the Blower motor should engage. If this doesn't happen see the Blower Motor Fault Tracing Section.

**Electrical Functions**

The electrical functions of the DC6000 are divided in a 400/480 V 3-Phase system and a 1-phase 230 V system. The 400/480 V 3-Phase system is used to power the Blower Motor and to power the Auxiliary power outlet used to power the connected grinder. The Blower Motor is equipped with an Hour Meter that measures its running time.

The 230 V system is generated by a transformer that's connected to the 3-phase and is used to power the air compressor and a PLC.

The air compressor is used to generate pressure to the pressure container which is used to clean the filter with the purge function.

The PLC controls on/off function for the blower motor, the manual / automatic purge function.

These functions are connected together according to the flowchart **XX**

## Simplified Electrical Schematic

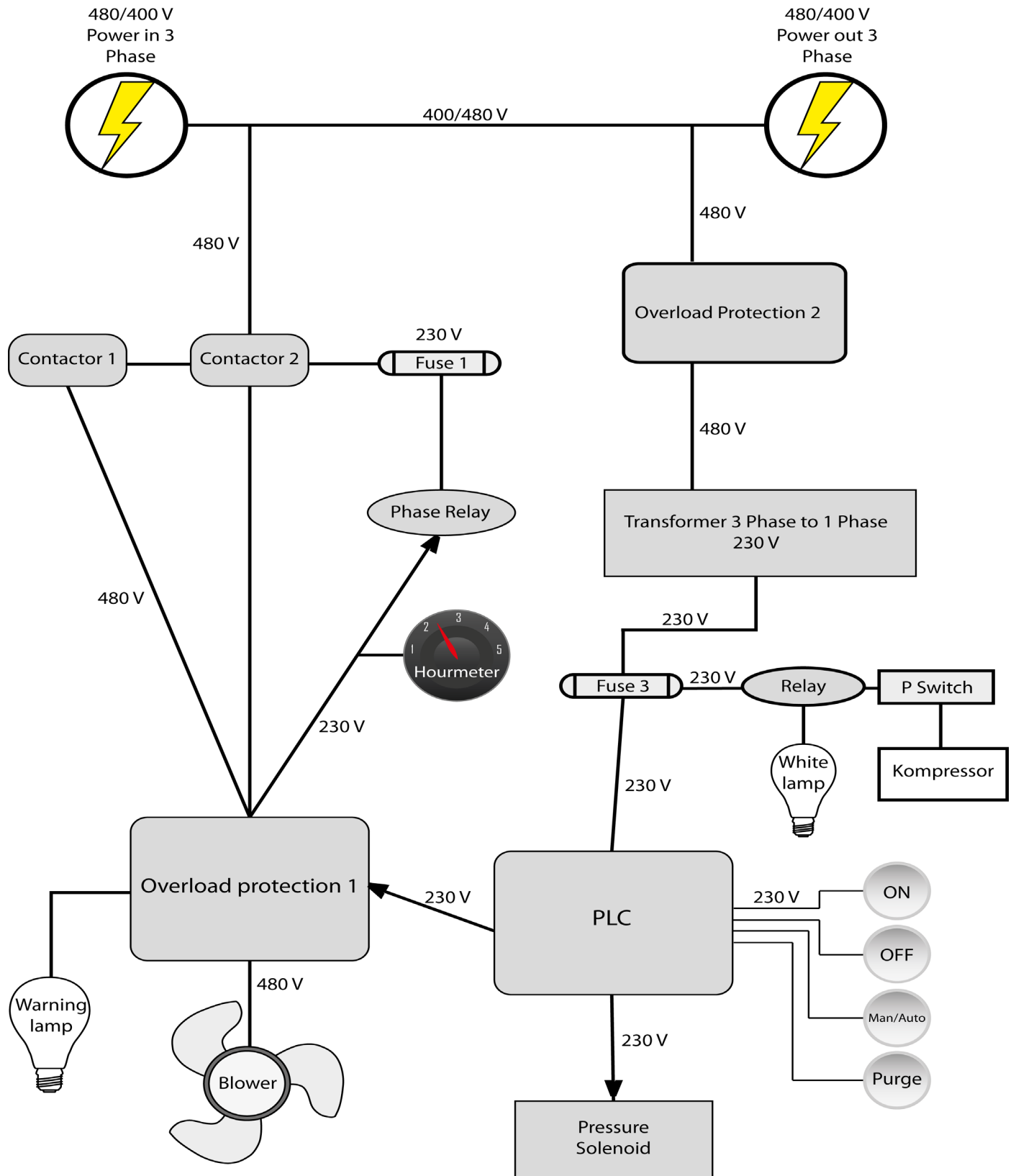

### Blower Motor

The blower motor is powered by the 400/480 V 3-phase system and is controlled by the PLC. The PLC sends a 230 V signal to the overload protection Q1 and it engages one of the 2 power contactors K1 and K2. The phase sequence relay K3 determines which one the contactors that engages according to how the phases in are connected. The overload protection Q1 is also monitoring the power output to the motor and will shut off if its limit is reached. If the Limit is reached the overload lamp will lit and the blower will shut off. The blower motor is connected to an hour meter which is used to record the running time of the blower.

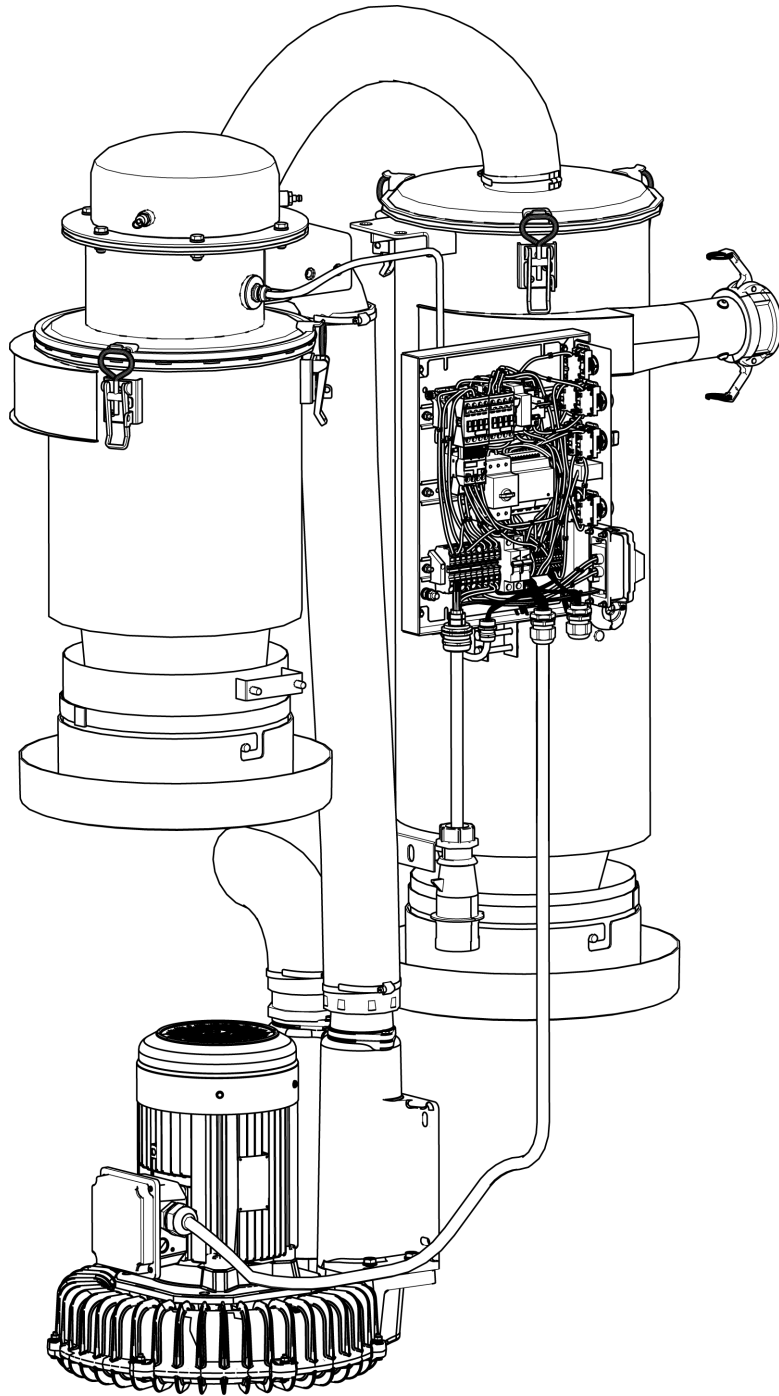



## Blower Motor Electrical Schematic

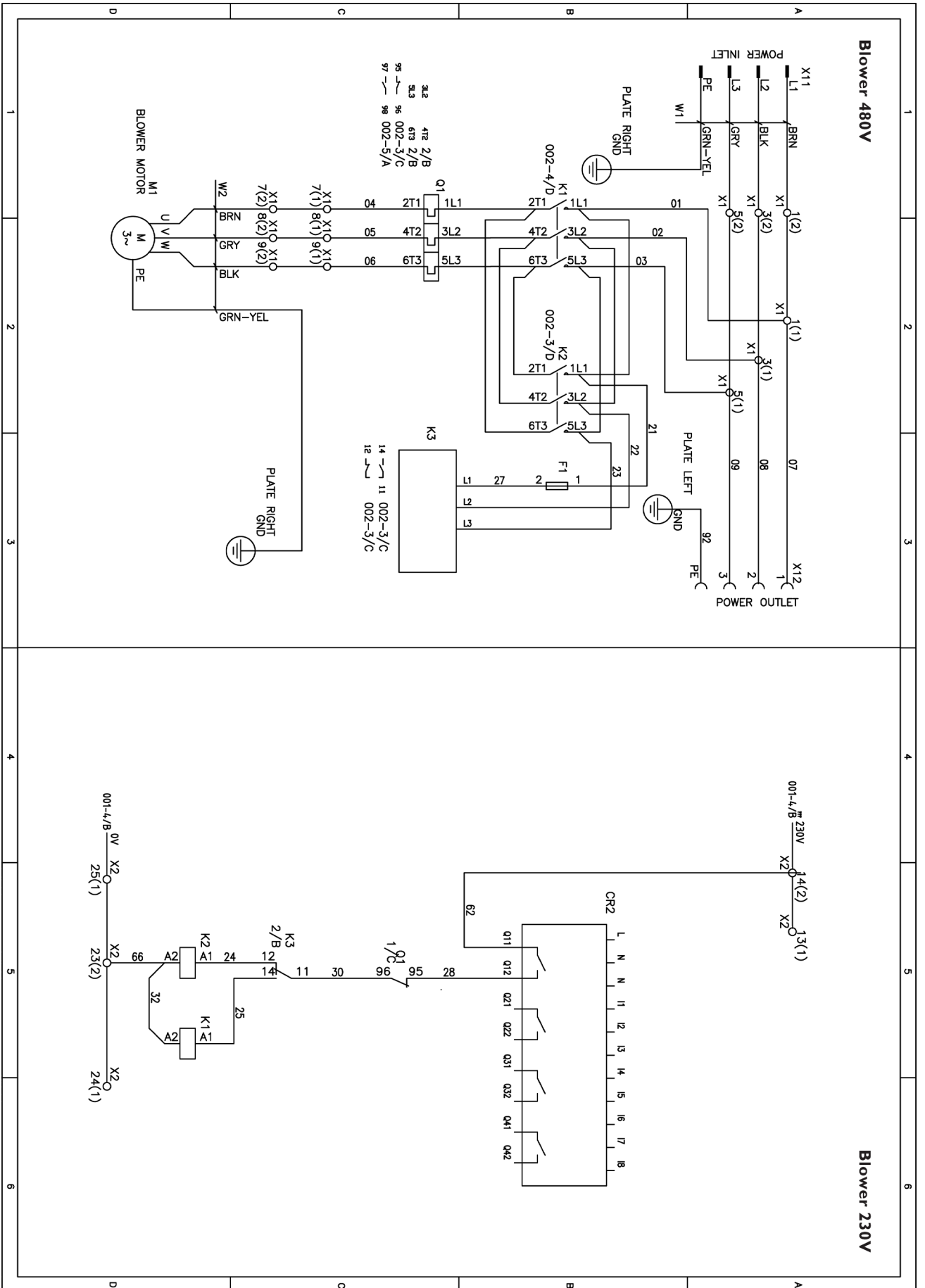

### Auxiliary Power Outlet

The auxiliary outlet is connected directly to the main power cable and is energized as soon as the main cable is connected to a power source.

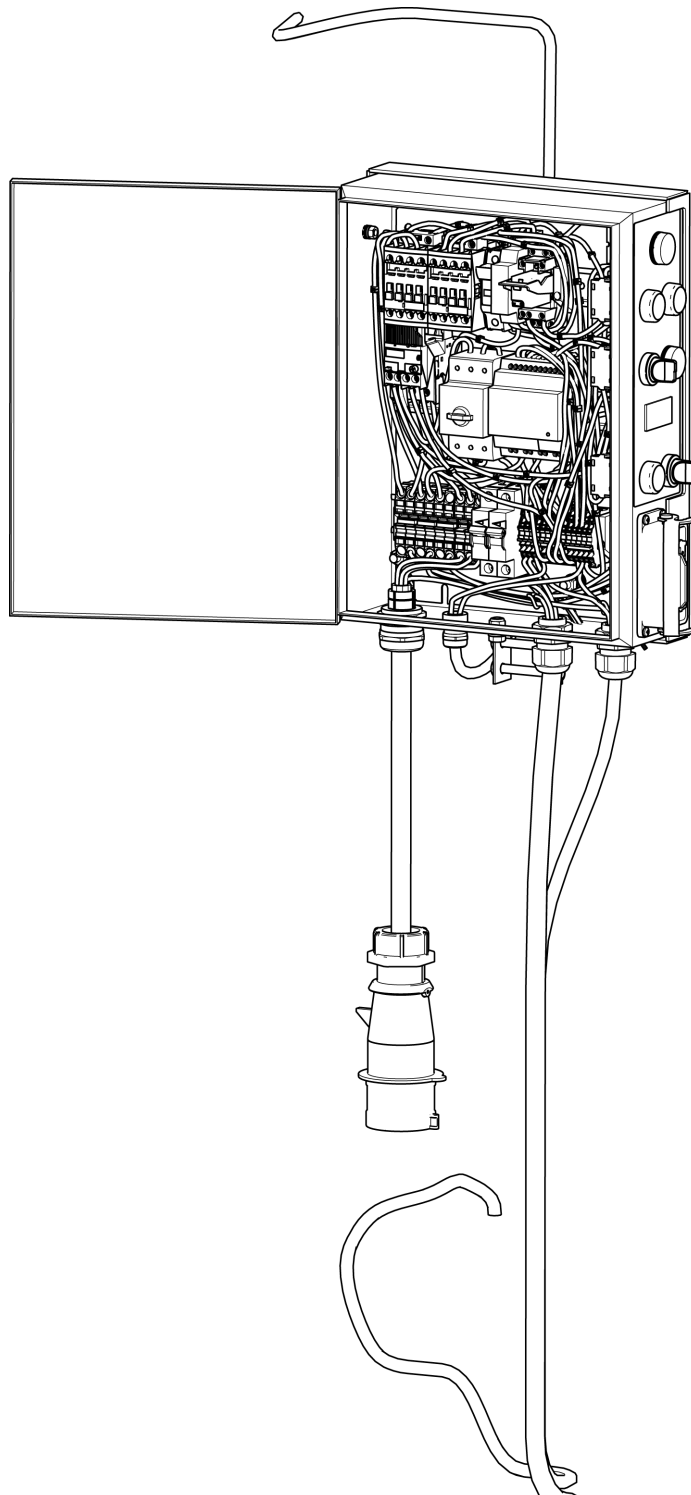

## Auxiliary Power Outlet Electrical Schematic

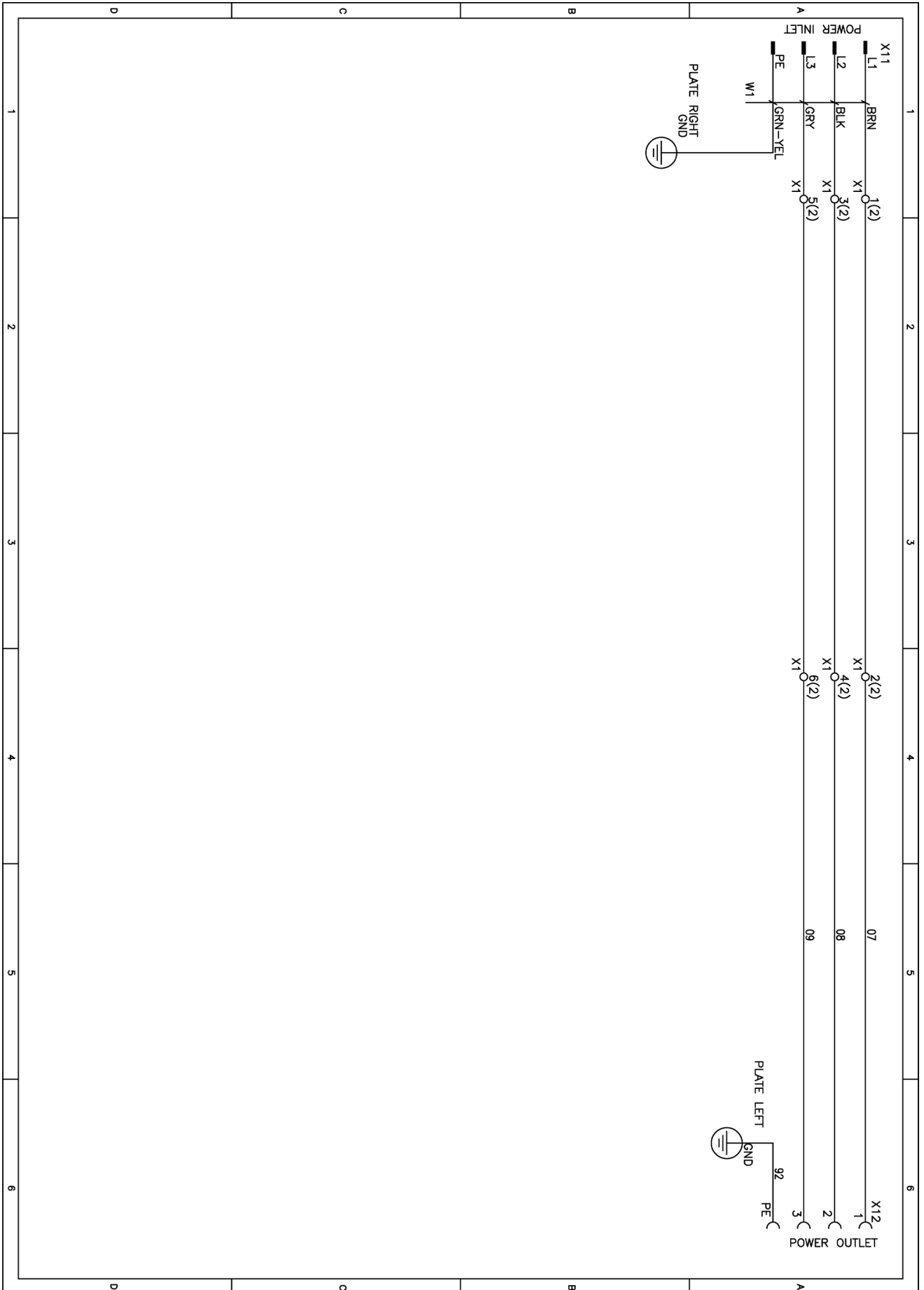

**PLC**

The PLC is powered by the 230 V transformer and is used to control the on/off function for the blower. And the manual/automatic purge function. Its input is controlled by the settings on the control panel. And its output is a 230 V control signal for the purge solenoid and to the blower. If the Purge settings are in manual mode the PLC will only send a 230V Purge signal to the solenoid valve when the Manual Purge button S3. When the Purge setting is in automatic mode the PLC will use its program settings to control the Purge function. The Purge will then clean the filter each time the blower is turned on and off, and for every 60 seconds during its running time..

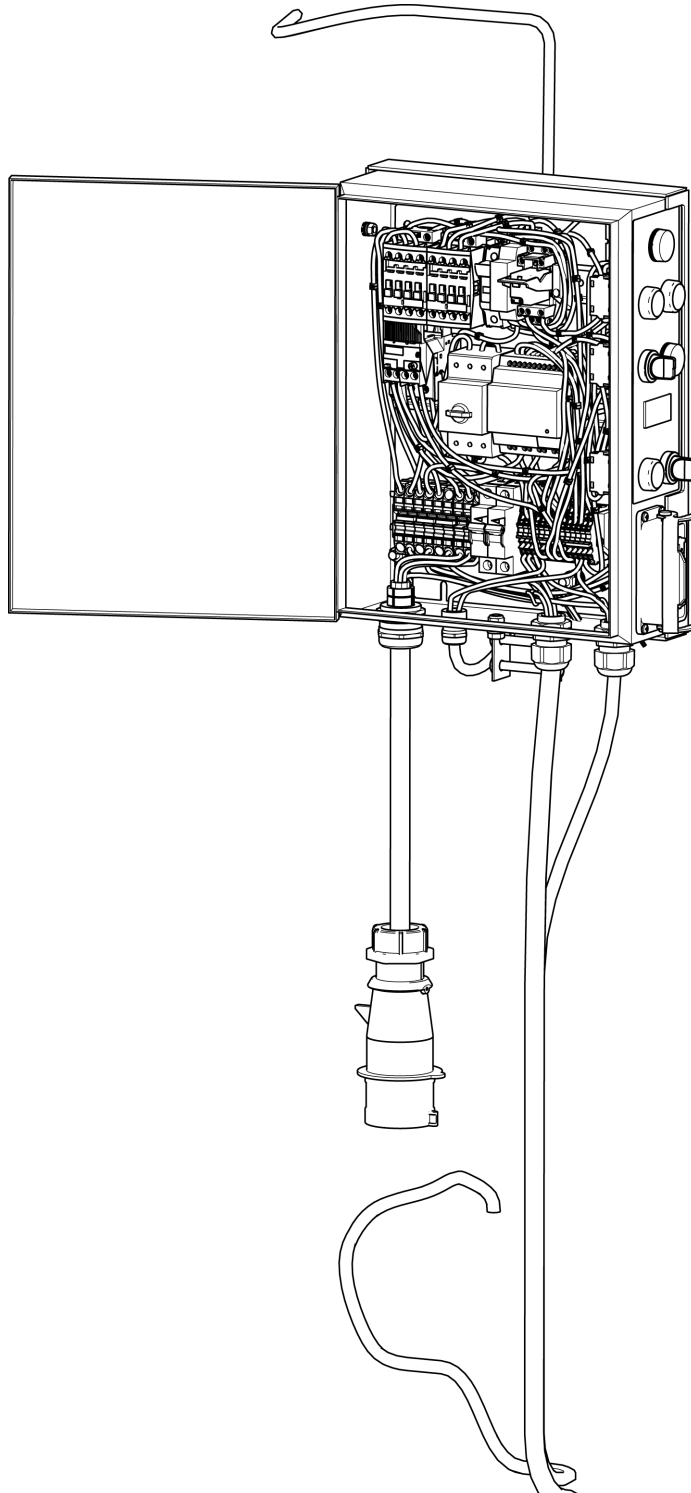

## PLC Electrical Schematic

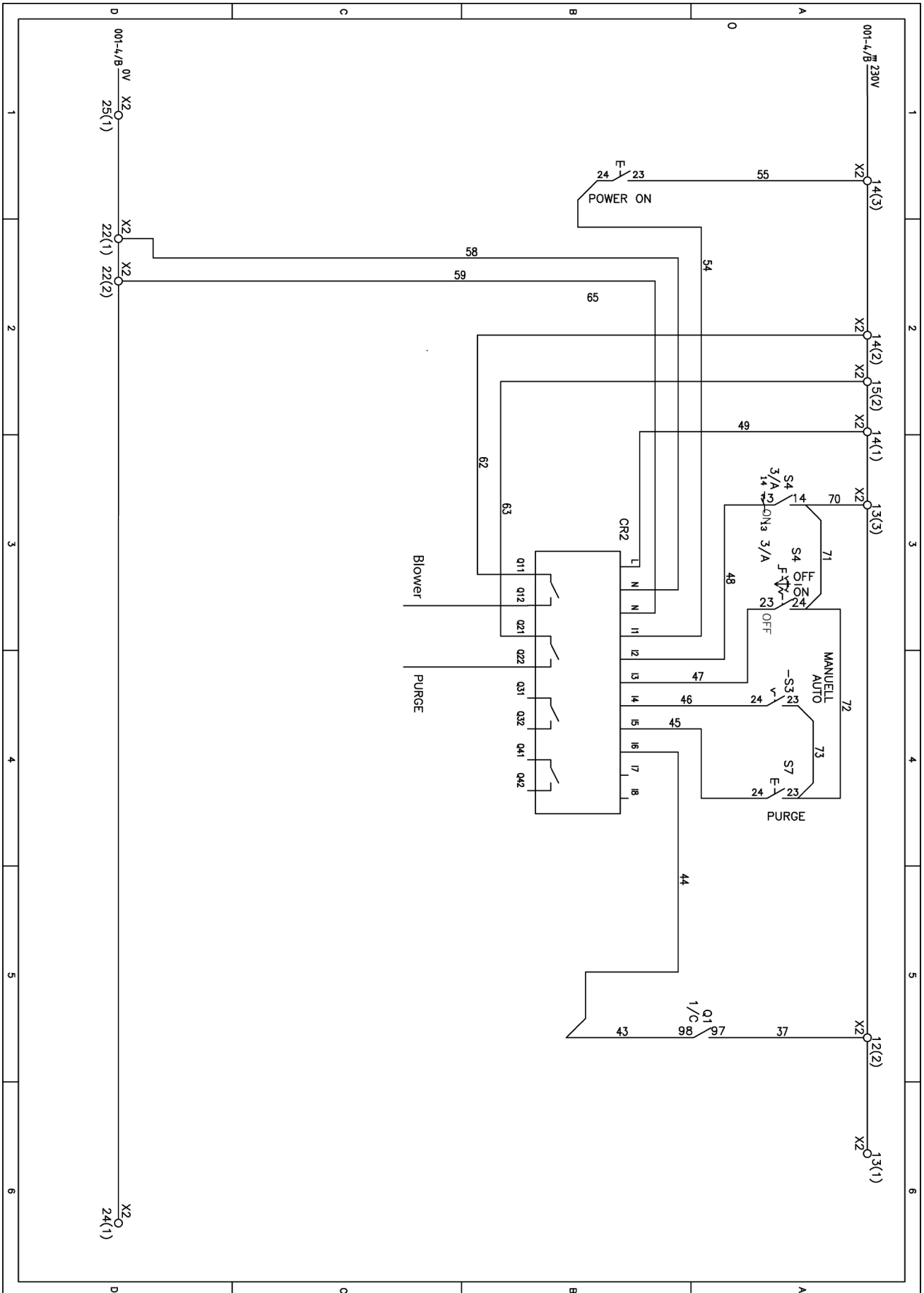

**Transformer 230V**

The 230V Transformer transforms 400/480V 3-phase power to 230V 1-phase power. The 230V is used to power the PLC, the Air Compressor and its pressure switch. All of the in/out signals from the PLC are also a part of the 230V electrical system..

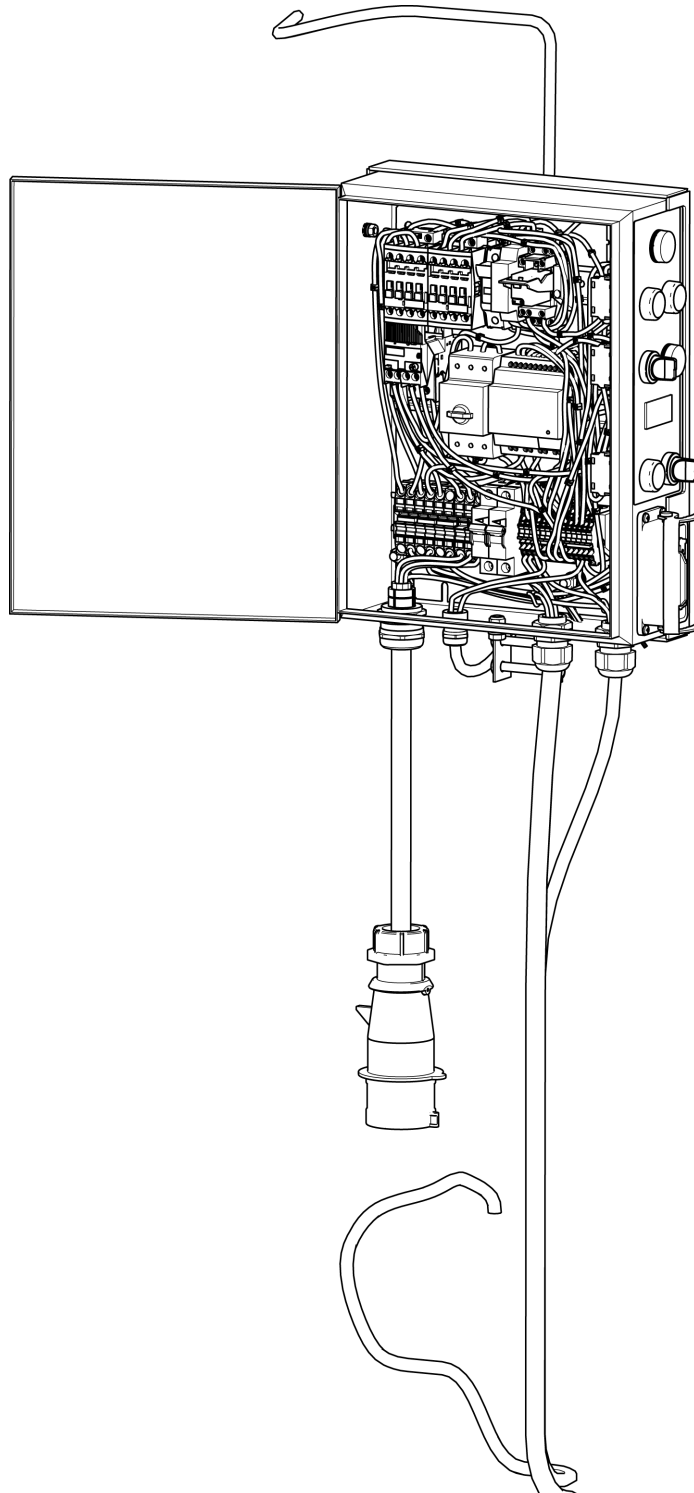

## Transformer 230V Electrical Schematic

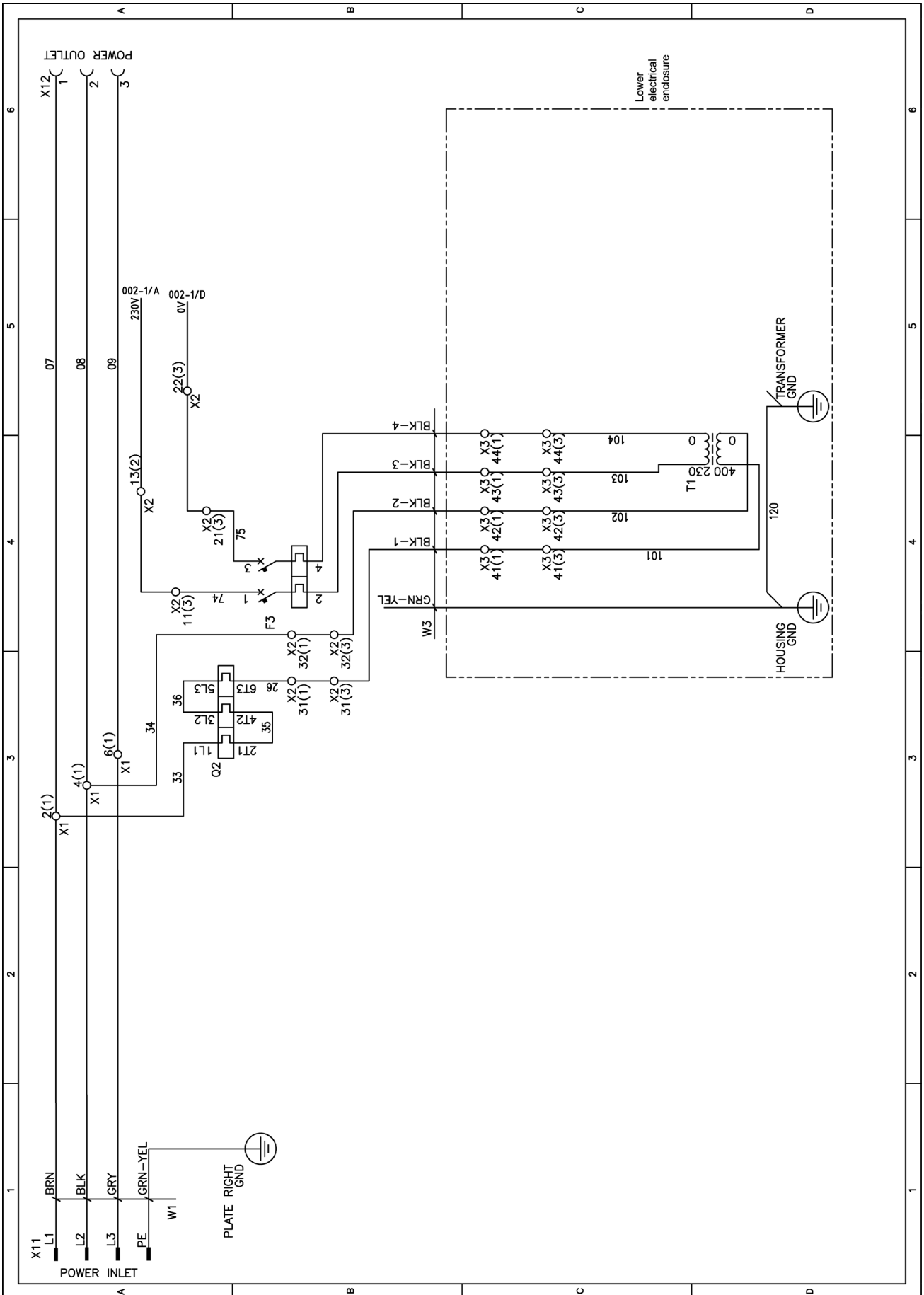

### Purge Function

The Purge function is the automatic filter cleaning system. It cleans the airfilter by releasing compressed air through the filter which allows the dust to fall down in the longopac bag. The Purge function can be in Automatic or Manual mode. When it's in Automatic mode the PLC programming will control the cleaning and when it's in Manual mode it will be executed by pressing the Purge button S3. The compressed air is generated by the air-compressor M2, and it releases air when the Solenoid Valve K5 gets a 230 V signal from the PLC (CR2). The Compressed air is contained in the air tank (XX9) and its controlled and managed by the pressure switch (S10).

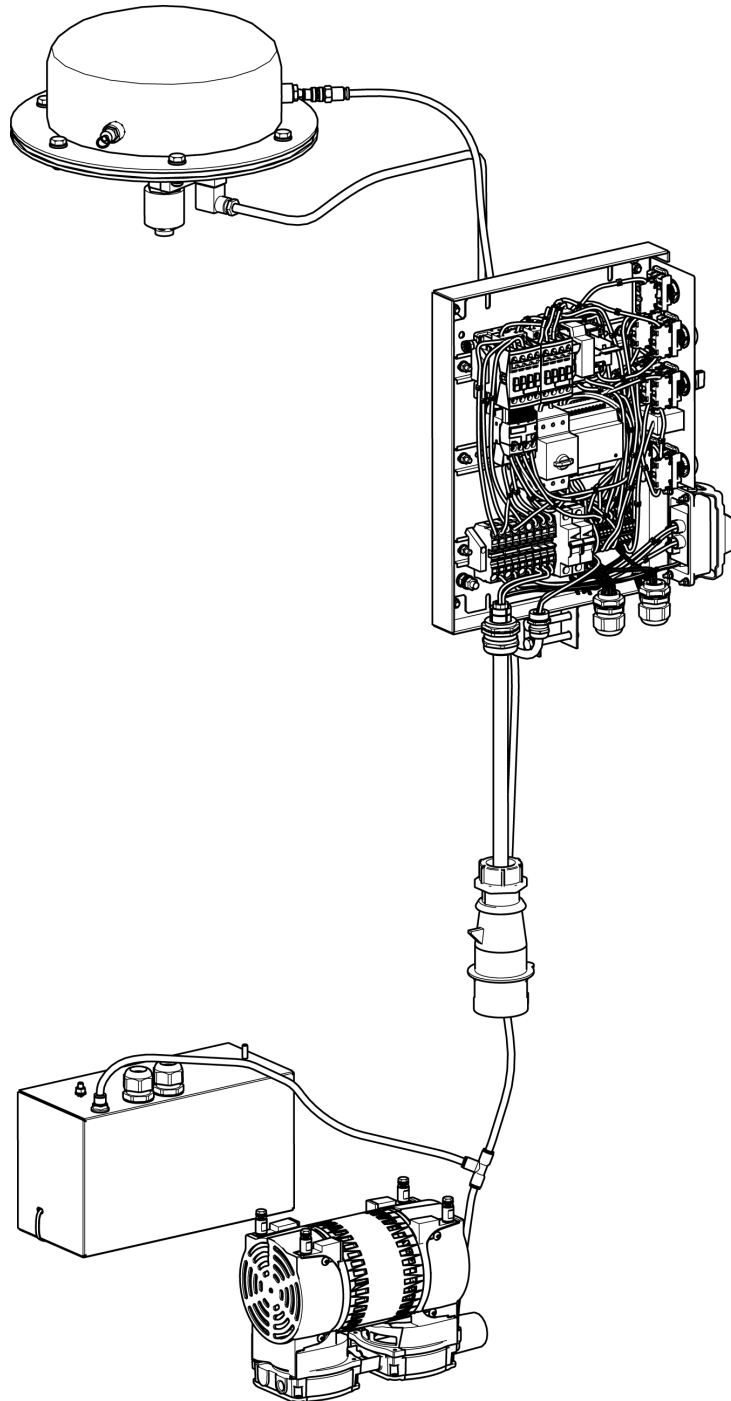



## Purge Function Electrical Schematic

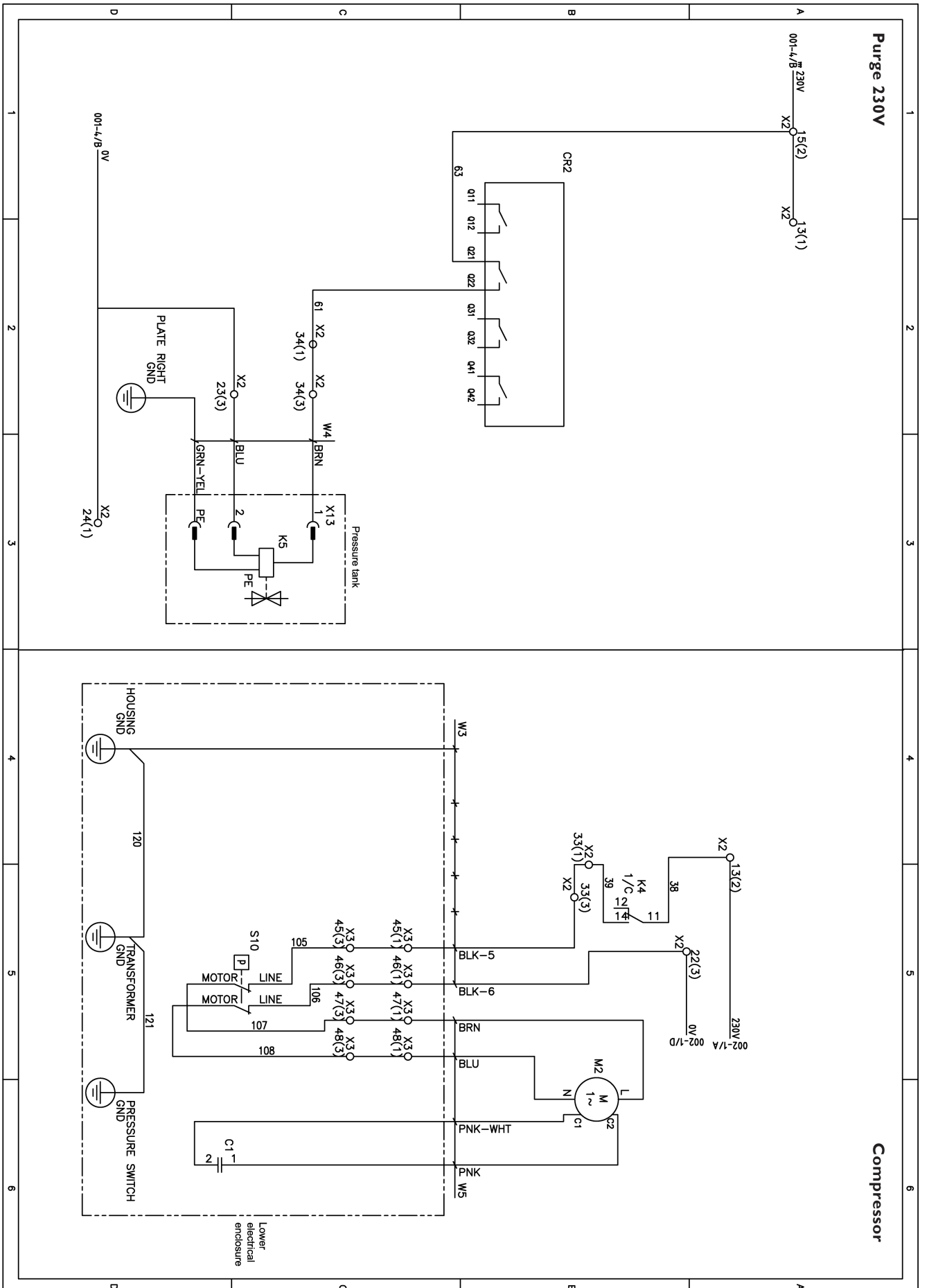

### Hour Meter

The Hour meter is used show the running time for the blower motor. Its mounted in the electrical cabinet and reads the signal between the Overload Protection (Q1) and the Phase sequence relay (K3).

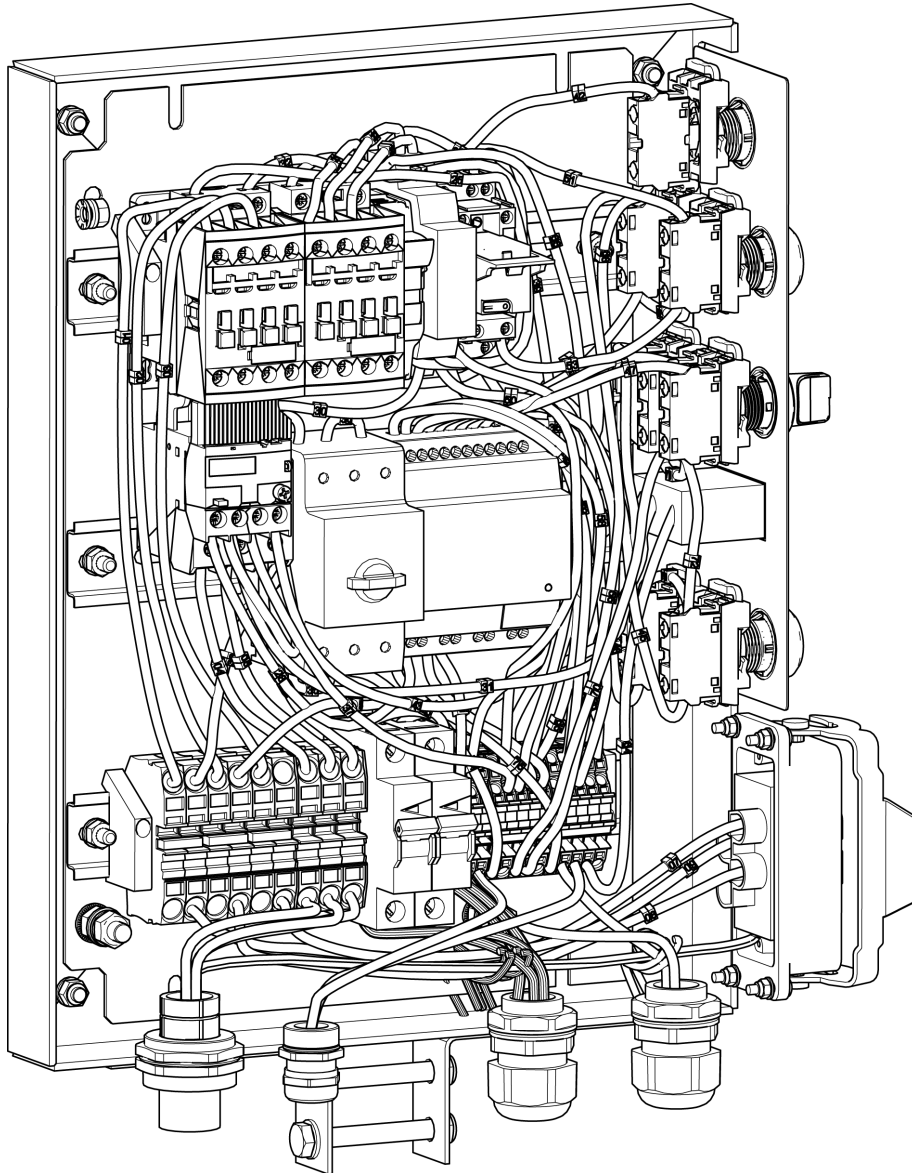

## Hour Meter Electrical Schematic

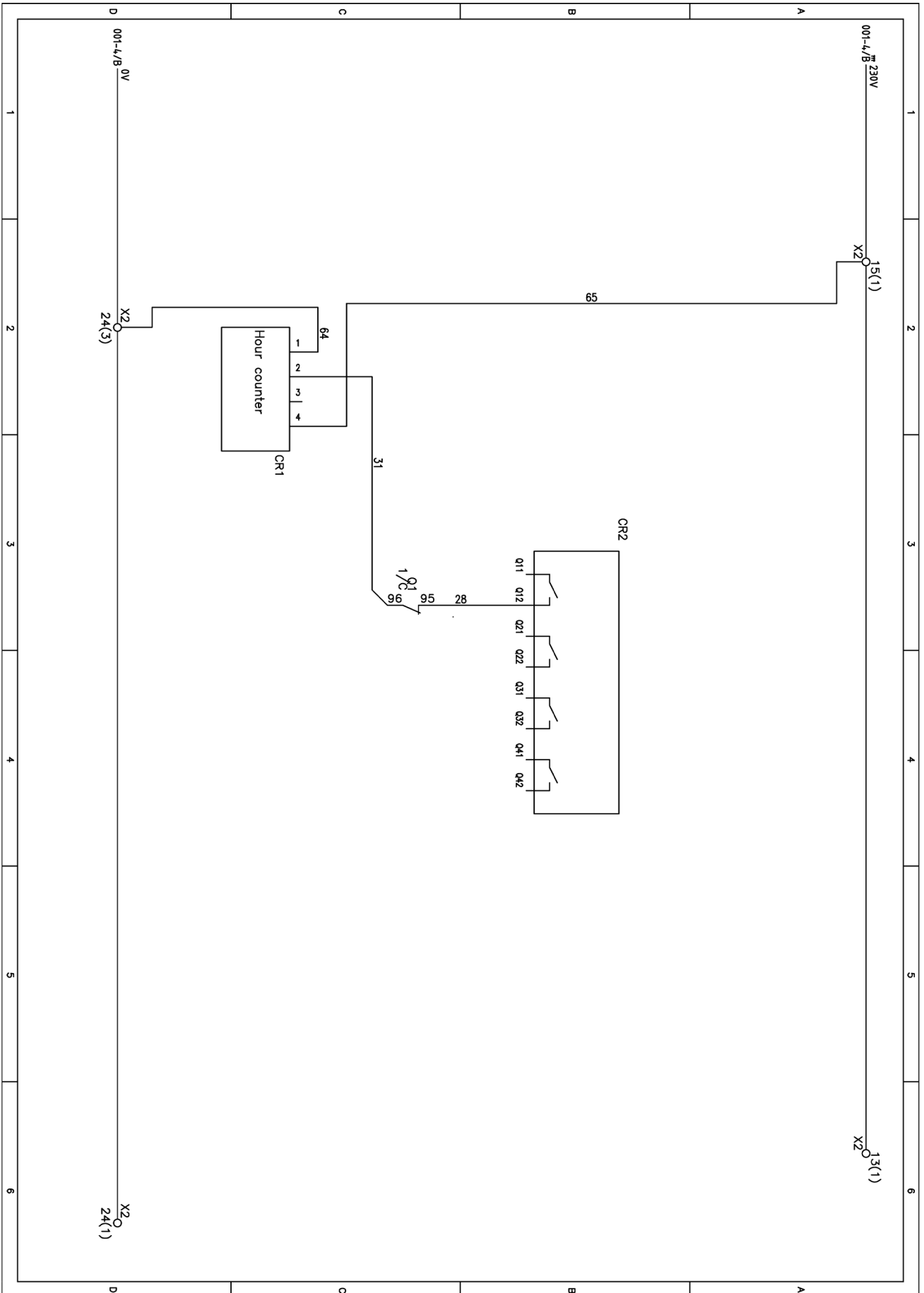

### Troubleshooting

**WARNING!** Most accidents involving machines occur during trouble shooting, service and maintenance as staff have to locate themselves within the machine's risk area. Prevent accidents by being alert and by planning and preparing the work.

The engine should be switched off during operations described in this chapter unless otherwise stated.

All checks involving electric components should only be performed by a licensed electrician.

Fault indication	Possible cause	Possible action
The machine does not run	The machine has no incoming or outgoing power.	Check that the power cable is connected and the machine turned on.
		Have a licensed electrician check the presence of power at the top of the left side contactor. If no power at the contactors, test for presence of power at the power source.
	Damaged cables.	Contact a licensed electrician.
	Circuit breaker has triggered.	Make sure the circuit breaker is active.
The machine makes a low humming sound when switched to ON	Phase error. Only two phases present. Switch off machine immediately to avoid motor burn-out.	Contact a licensed electrician.
	Dust in the motor impellers.	Contact a licensed electrician.
	Burned out motor.	Contact your service agent.
The machine is blowing instead of sucking when on a different power source	Phase relay fault.	Unplug the machine and have a licensed electrician change L1 and L3 on the motor and test for suction to confirm failed phase relay.
The machine will run but there is not power at the accessory power outlet	Unit not correctly connected.	Check that the unit is correctly connected and properly powered up. (Eg. safety breaker and emergency stop are in the correct position on the grinder.)
	Contact problems in electrical cabinet.	Contact a licensed electrician.
The machine does not have much suction	The filter is blocked	Clean or replace the filter.
	Cyclone is clogged.	Use compressed air or a brush to clean the cyclone screw and container.
The machine is blowing dust out the exhaust	The filter is not correctly fitted.	Ensure the filters are fitted correctly.
	The filter has become detached.	Ensure the filters are fitted correctly.
	Holes or perforations in the cone filter.	Replace the filter.
Purge does not clean filter and/or does not work.	Compressed air hose has come loose or broken.	Check the hoses from the compressor, pressure switch and purge tank.
	Filter on compressor is clogged.	Clean or change the filter on the compressor.
Compressor running continuously.	Filter on compressor is clogged.	Clean or change the filter on the compressor.

\*If there are large amounts of dust in the filter housing it means that there is some kind of problem with the filter.

**10. SERVICE AND MAINTENANCE**

The following lists contains service procedures to be performed on the CD 6000 by the servicing workshop. Maintenance procedures normally performed by the owner (daily service) are described in the Operator's manuals.

**Service**

	<b>Daily</b>	<b>Weekly</b>
Check that the machine's safety equipment is unharmed. See instructions in section "Machine's safety equipment."	X	
Make sure the cord and the extension cord are intact and in good condition.	X	
Clean the machine exterior.	X	
Check the filter and shake out the dust when needed. If necessary, wash the filter with water according to Husqvarna's recommendations. Never clean the filter using air pressure. See Cleaning / replace filters in OM	X	
Check the dust level inside the filter housing.	X	
Check the cyclone and holder.		X
Check the rubber sealing on the cyclone.		X
Make sure the container net on the cyclone is clean.		X

### Filter

The filter is made of a polyester material and can be washed with water as necessary. Change filter after 500 hours or after 6 months.

- In order to avoid destruction of the finish or ePTFE membrane clean the filter elements with a gentle soft jet of water. A strong/sharp jet will destroy the ePTFE membrane. The cleaning can be supported by a soft brush.
- Wash the filter elements from top to bottom. Avoid rubbing or scrubbing on selected spots.
- Dry the filter elements carefully. Approximately one week at a temperature of 15-20 °C, or at 70 °C during 14 hours in the oven. It is important that they are 100% dry.
- After washing in above mentioned way, the filter elements can be used again at low pressure drop. The life time after washing is approximately 60-70 % of the life time in new condition.

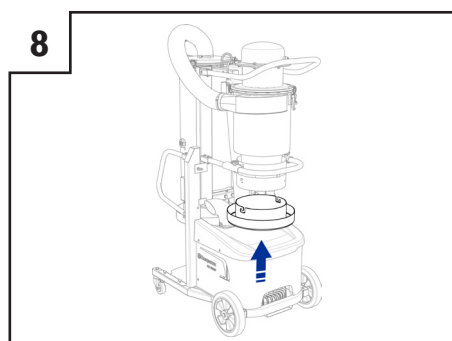
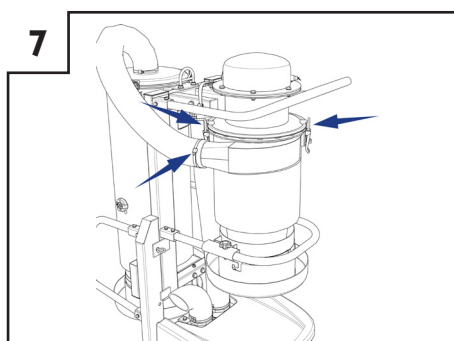
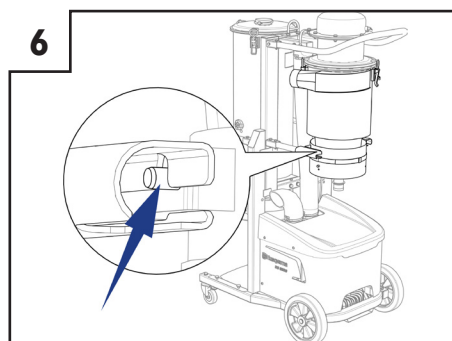
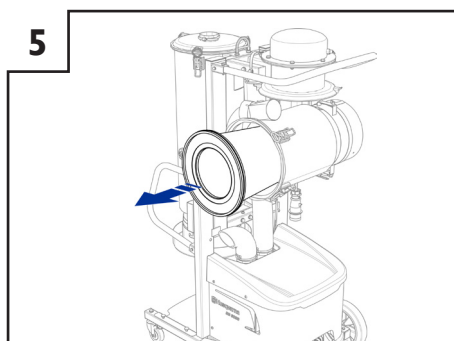
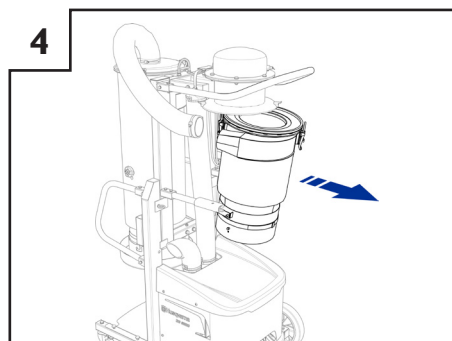
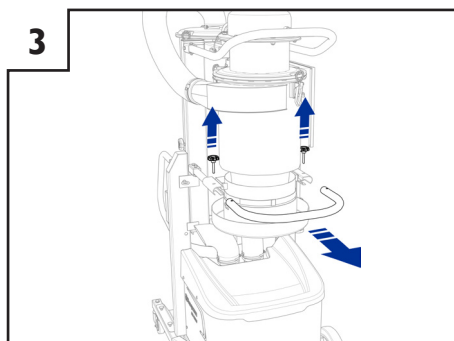
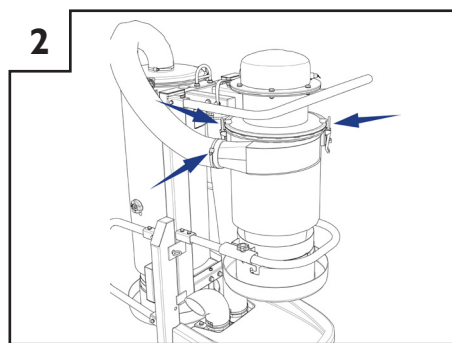
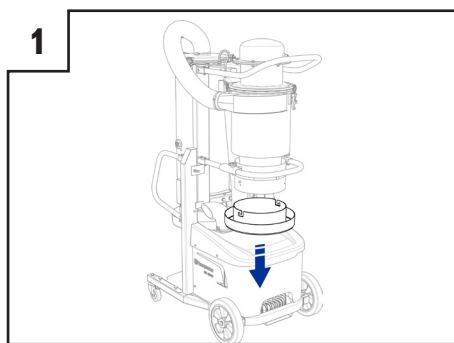

### Filter Maintenance

1. Remove the longopac holder.
2. Loosen the clamping brackets for the lid to the filter container.
3. Loosen the handle by loosening the knobs.
4. Grasp the lower rim of the filter container and lift the container out of its guide groove. The filter container does not fall down but rests on the handle.
5. Pull out the filter. Clean and dry the filter or fit a new one. The filter is a conical shape and the wider section should be at the top of the filter container.
6. Replace the filter container in its guide groove on the handle.
7. Tighten the container using the clamping brackets and connect the hose connector to the filter container.
8. Insert the longopac holder.

**11. REPAIR INSTRUCTIONS**

<b>11.1. Covers</b>	
Removing the Front Cover.....	32
<b>11.2. Electric</b>	
Replacing the Main Cable .....	33
Removing Terminal Block X1.....	33
Removing Terminal Block X2.....	34
Removing Contact Blocks H1, H2, S1, S2, S3, S4, S7 .....	34
Removing Fuse F3 .....	34
Removing Fuse F3 .....	35
Removing Relay K4.....	35
Removing Phase Sequencing Relay K3.....	35
Removing Overload Protection Q2 .....	35
Removing PLC CR2.....	36
Removing Contactors K1, K2, Q1.....	36
Replace Transformer.....	37
Remove Pressure Switch.....	37
<b>11.3. Motor</b>	
Remove Air Hose.....	38
Removing Generator .....	39
Removing Motor .....	40
<b>11.4. Filter</b>	
Replace Filter Valve .....	41
Replace Filter Sealing.....	42
<b>11.5. Electrical Drawings</b>	
Controls CE.....	43
Controls US.....	44
Power CE .....	45
Power US.....	46

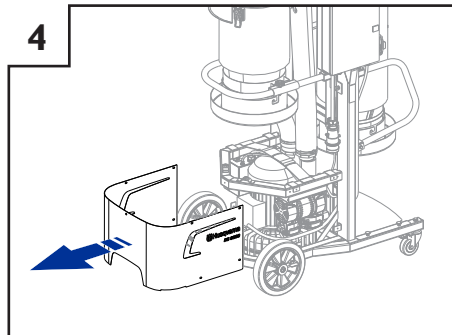
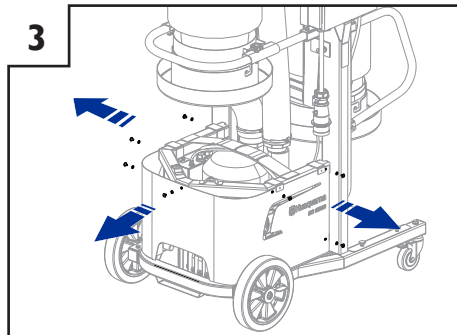
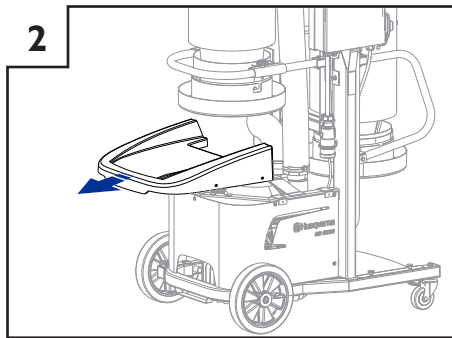
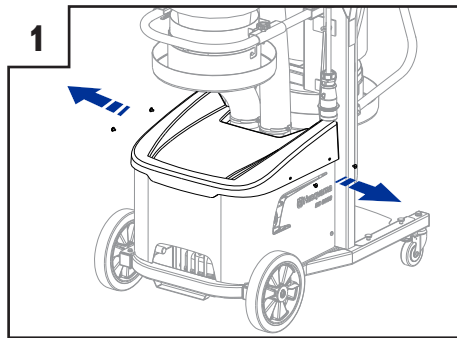

## 11.1. COVERS

### Removing the Front Cover



1. Remove the four screws holding the top cover.
2. Lift the top cover up and outwards.
3. Remove the seven screws holding the front cover.

Remove the front cover by pulling it out.

Reverse steps for assembly.



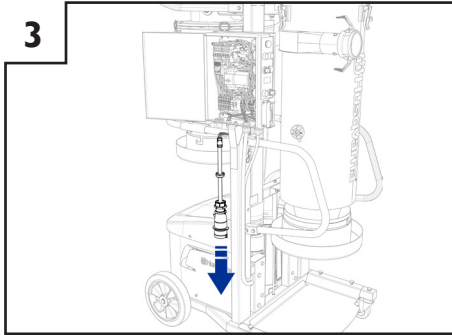
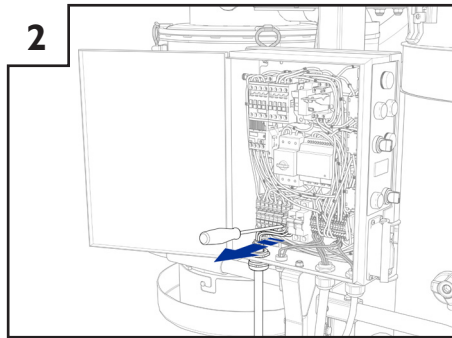
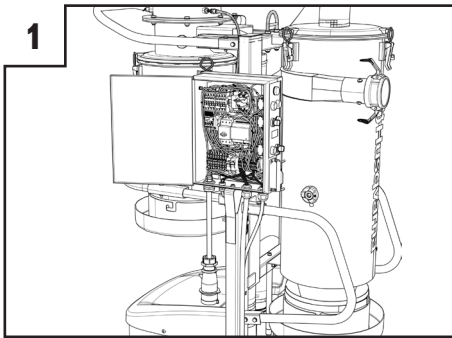

**11.2. ELECTRIC**  
**Replacing the Main Cable**

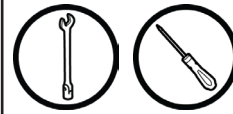

1. Open the electrical box.
2. Remove the cables.
3. Unscrew the cap and pull out the main cable.

Reverse steps for assembly.

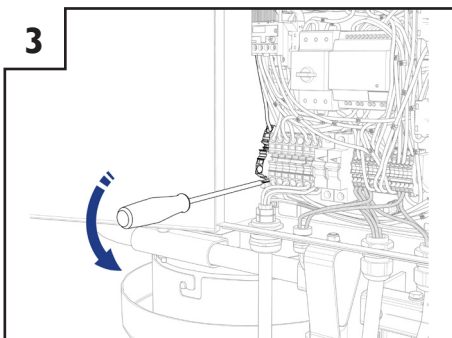
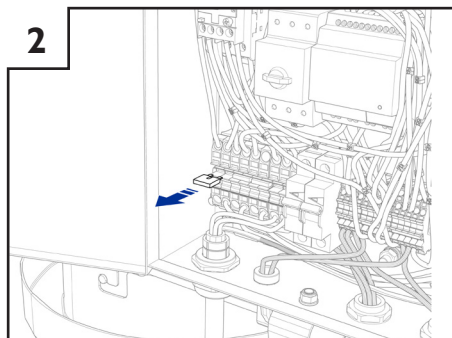
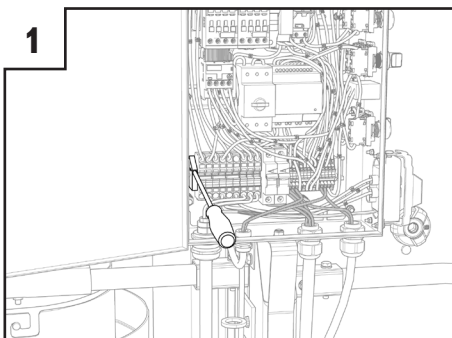

**Removing Terminal Block X1**



1. Remove the Clamp using a screwdriver.
2. Remove the 2-way Jumper Bar by pulling it out.
3. Pry the Terminal Block of by using a flat crewdriver.

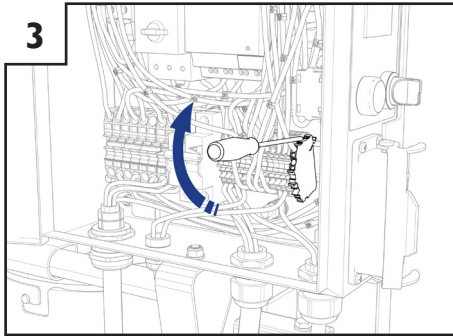
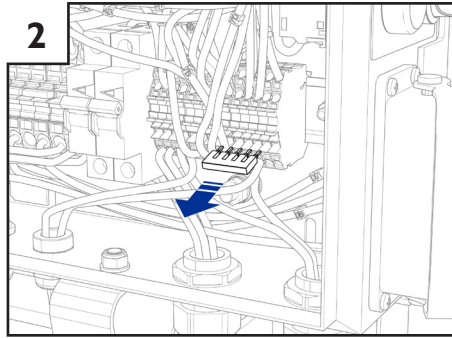
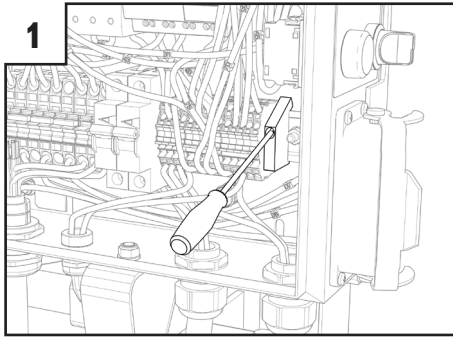

**Removing Terminal Block X2**



1. Remove the Clamp using a screwdriver.
2. Remove the 5-way Jumper Bar by pulling it out.
3. Pry the Terminal Block of by using a flat crewdriver.

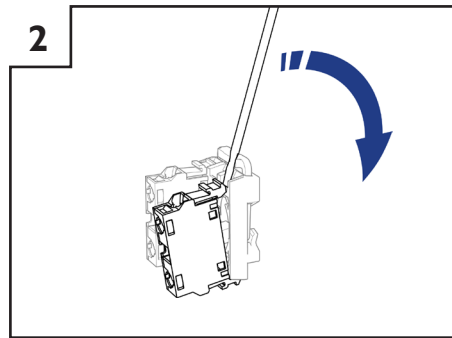
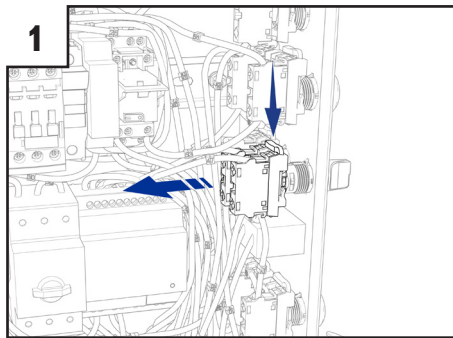

**Removing Contact Blocks H1, H2, S1, S2, S3, S4, S7**



1. Remove the Contact Blocks by pushing the button on the block holder down.
2. Pry the Terminal Block of by using a flat crewdriver.

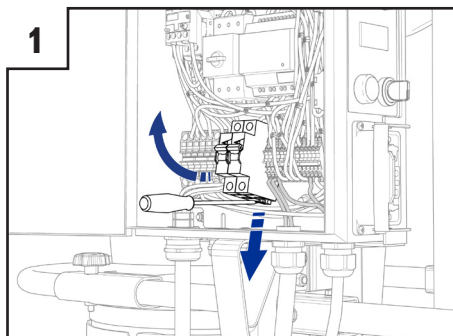

**Removing Fuse F3**



1. Remove the Contact Blocks by pushing the button on the block holder down.
2. Pry the Terminal Block of by using a flat crewdriver.

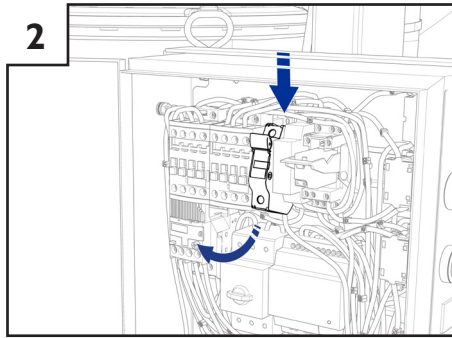
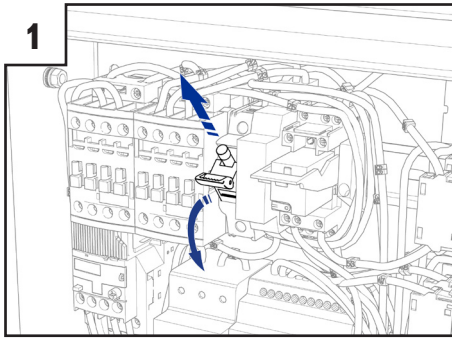

**Removing Fuse F3**

1. Remove the Fuse by opening the fuse holder and pull the fuse out.
2. Remove the Fuse holder by pushing it down and turning it out.

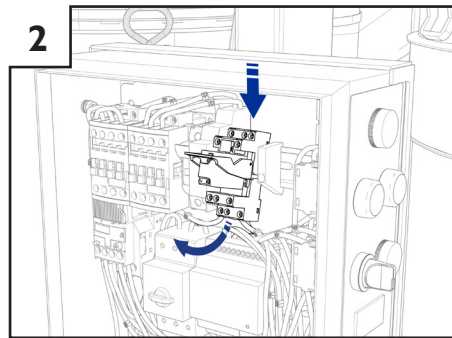
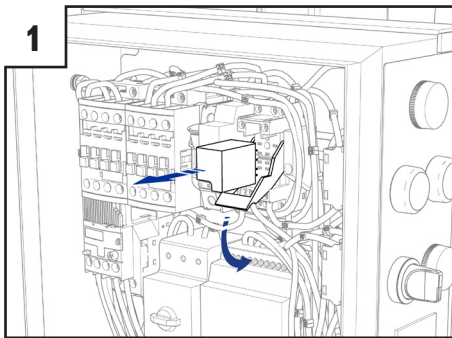

**Removing Relay K4**

1. Remove the Relay by flipping the plastic holder and pull the relay out.
2. Remove the Relay Socket by pushing it down and turning it out.

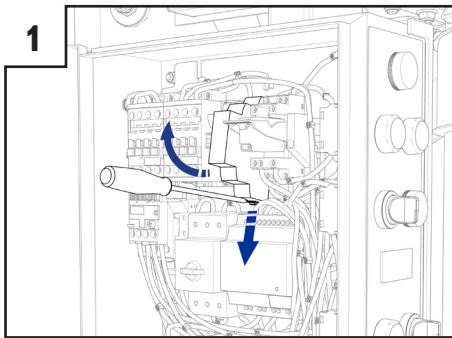

**Removing Phase Sequencing Relay K3**



1. Remove the Phase Sequencing Relay by pulling down the lock underneath with a screwdriver and turn it out.

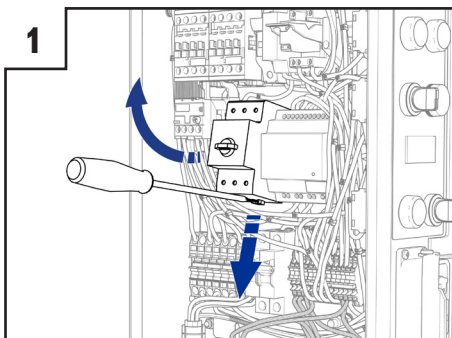

**Removing Overload Protection Q2**

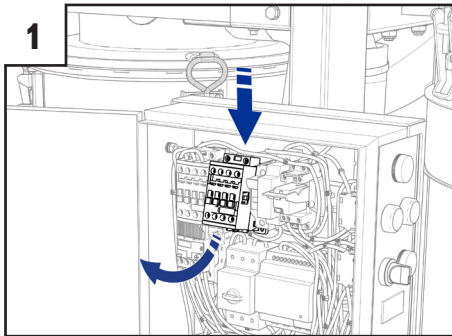
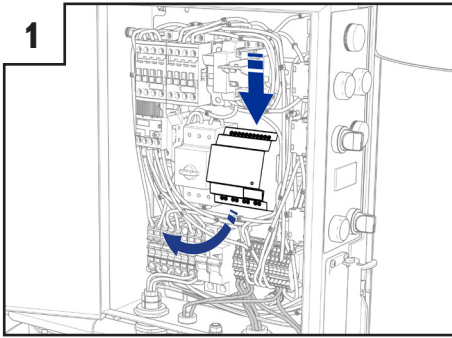

1. Remove the Overload Protection Pkzmo by pulling down the lock underneath with a screwdriver and turn it out.

**Removing PLC CR2**

1. Remove the PLC Eaton by pushing it down and turning it out.

**Removing Contactors K1, K2, Q1**

1. Remove the Contactor by pushing it down and turning it out.

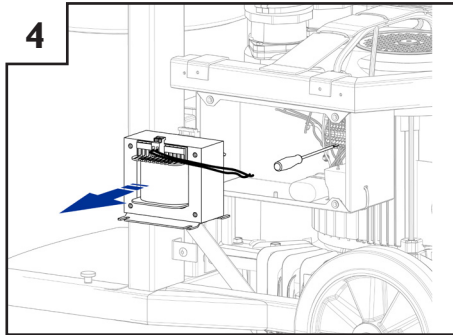
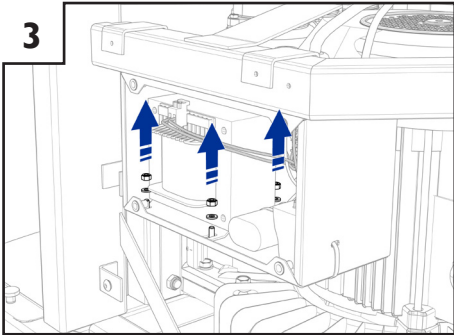
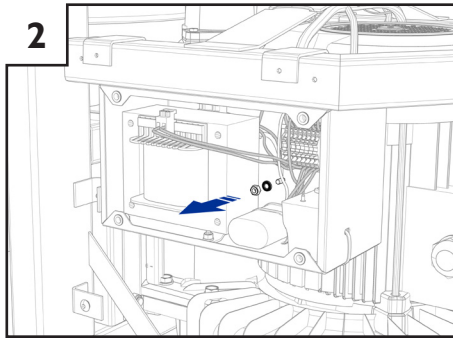
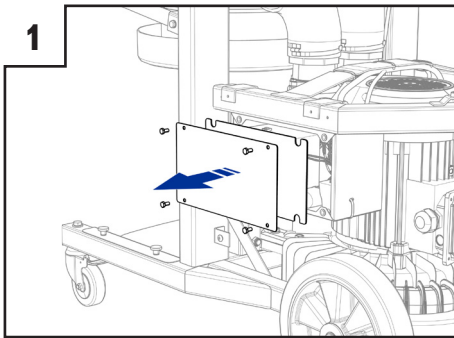

**Replace Transformer**

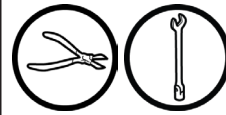

First see **Removing the Front Cover (p. 32)**

1. Remove lid and seal with four screws.
2. Remove ground cable with nut and washer.
3. Remove the three locking nuts and washers.
4. Remove the two cables from the Terminal Blocks using a flat crewdriver. Then lift the transformer out.

Reverse steps for assembly.

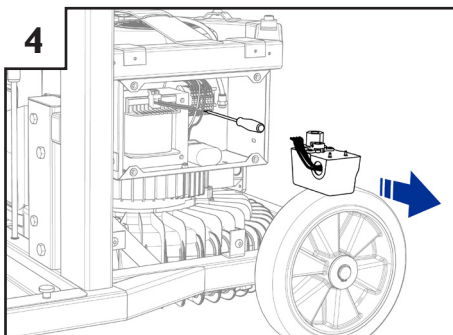
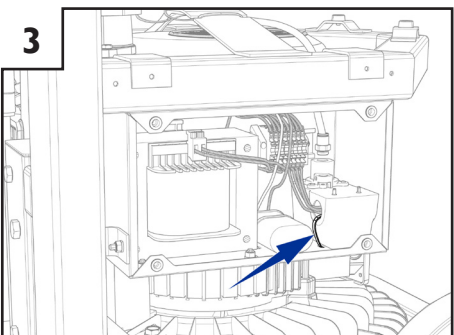
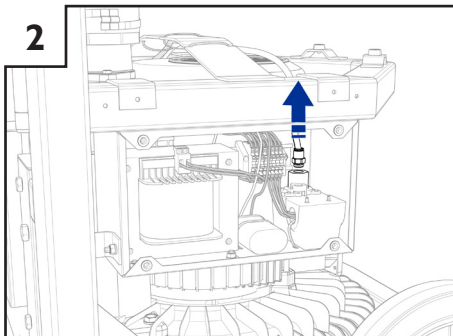
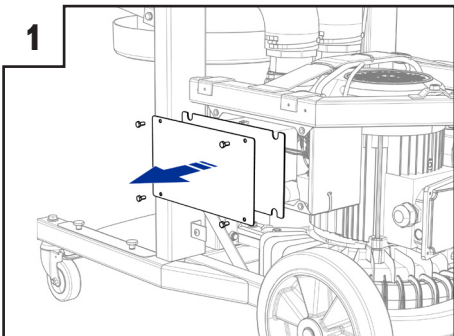

**Remove Pressure Switch**

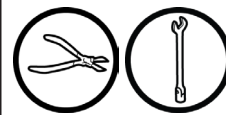

First see **Removing the Front Cover (p. 32)**

1. Remove lid and seal with four screws.
  2. Remove the connector.
  3. Cut the strap.
- Remove the switch.

Reverse steps for assembly.

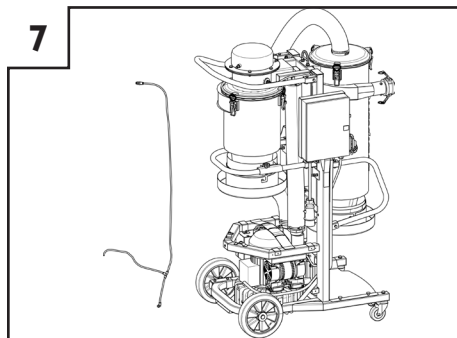
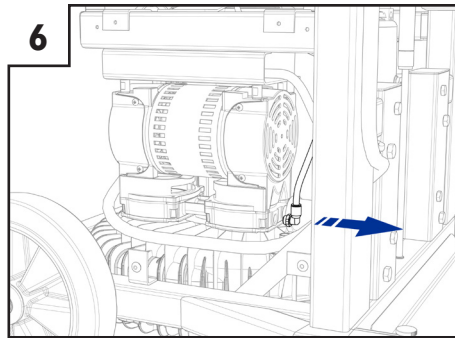
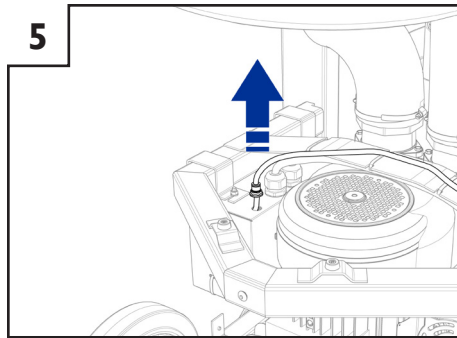
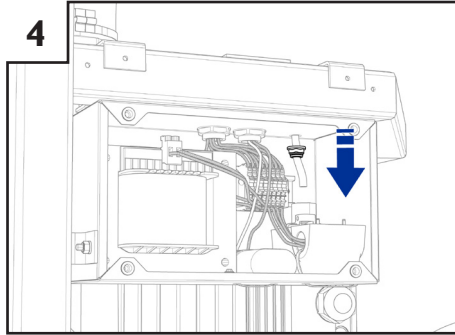
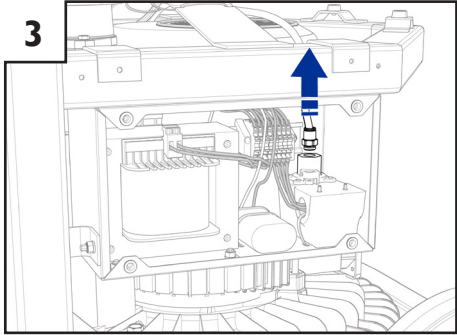
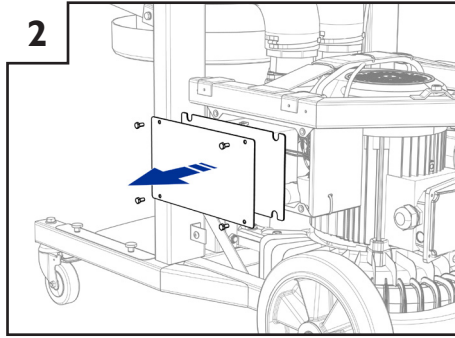
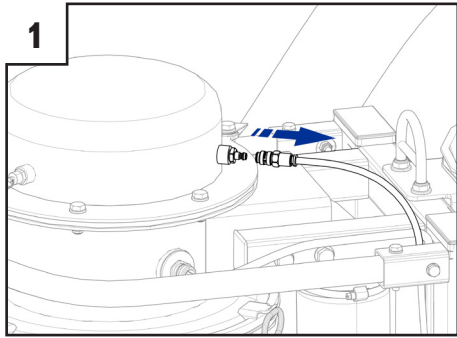

**11.3. MOTOR**  
Remove Air Hose



First see [Removing the Front Cover \(p. 32\)](#)

1. Remove the connection from the top cap.
2. Open the electrical box by removing the four screws from the lid.
3. Disconnect the hose from the switch and remove the connection.
4. Remove the connector by unscrewing it and thread the hose through the connector.
5. Remove the connector and hose.
6. Disconnect the hose from the generator.  
Thread the hose out.

Reverse steps for assembly.

## Removing Generator



First see [Removing the Front Cover \(p. 32\)](#)

1. Remove lid and seal with four screws.
2. Remove all 4 wires to the Compressor Capacitor and the Valve connector, X3
3. Unscrew the cable connector and pull the wires out.
4. Cut the cable holders.
5. Unscrew the 4 screws holding the generator.
6. Lift the generator out.

Reverse steps for assembly.

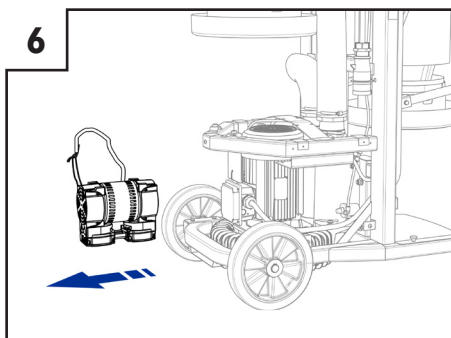
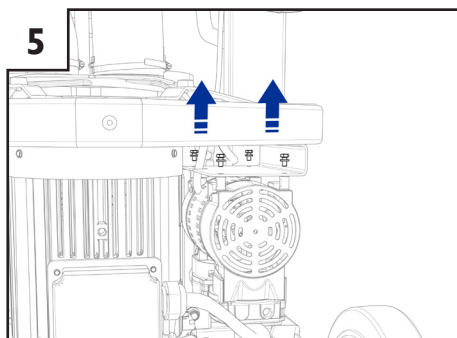
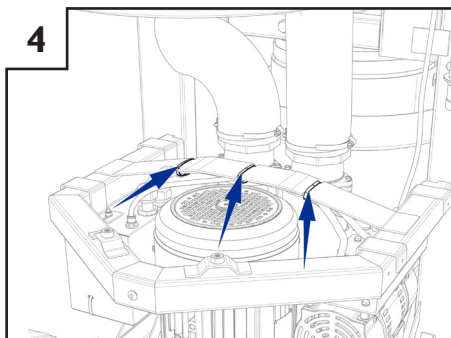
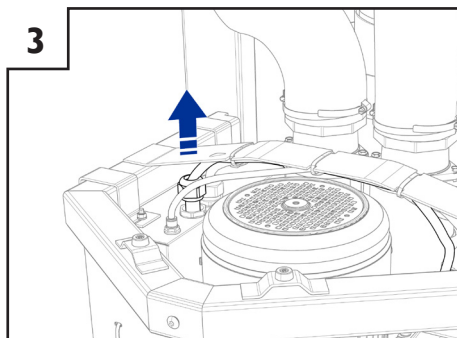
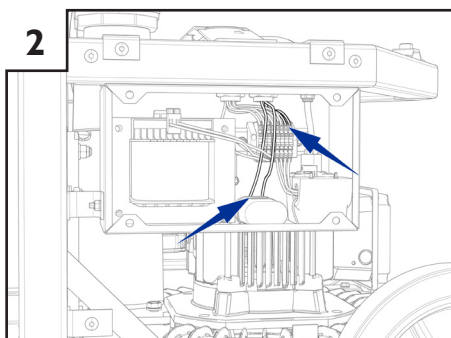
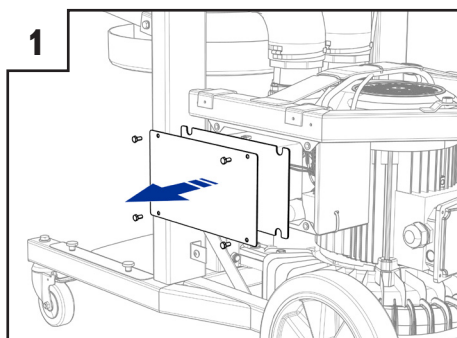

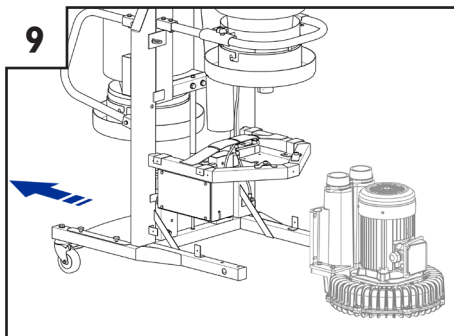
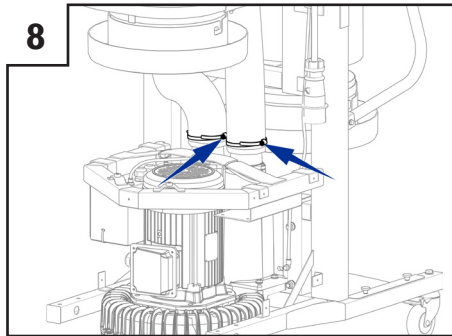
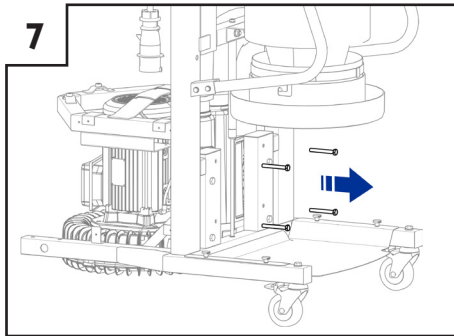
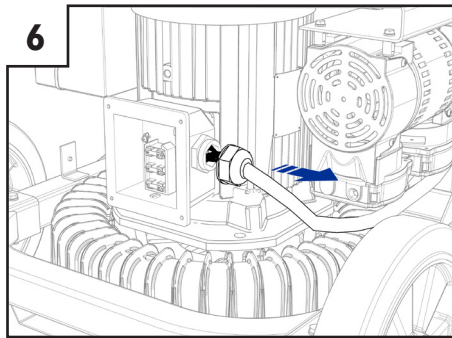
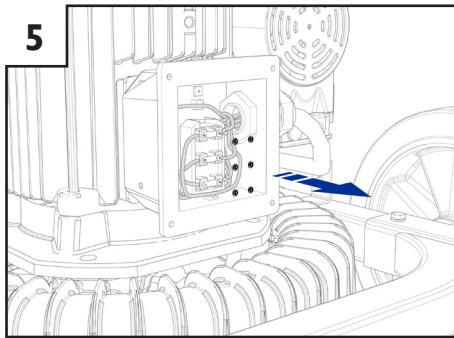
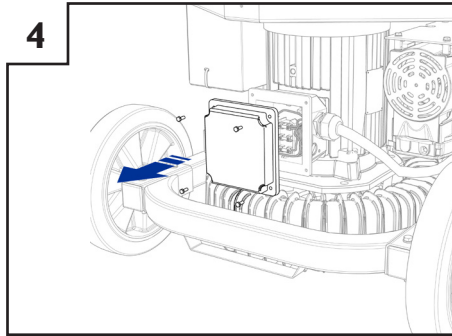
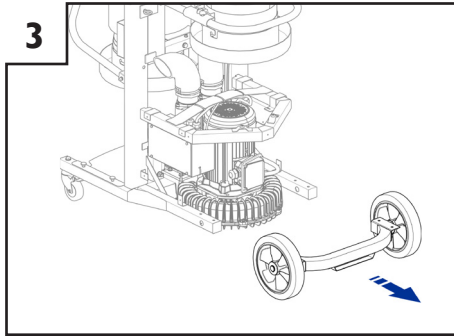
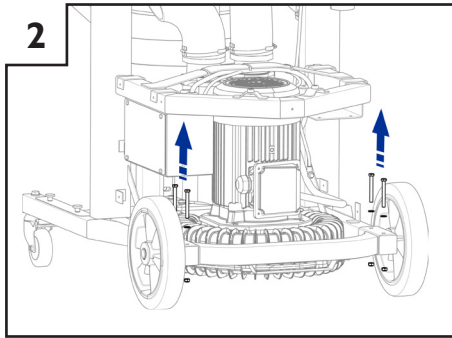
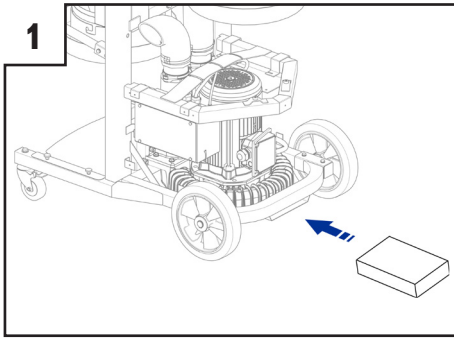

Removing Motor

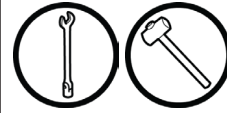

First see [Removing the Front Cover](#) (p. 32)



High Voltage

1. Slip a 2"4 under the motor.
2. Unscrew the four screws holding the front end of the frame.
3. Remove the loose frame.
4. Open up the electrical box on the motor.
5. Disconnect the cables inside.
6. Unscrew the power cable and remove it.
7. Unscrew the four screws holding the motor.
8. Remove the two hose clamps.
9. Move the frame back and leave the motor on the board.

Reverse steps for assembly.



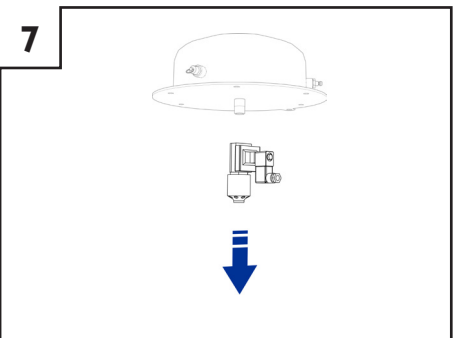
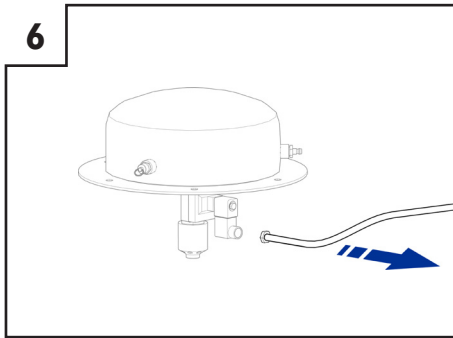
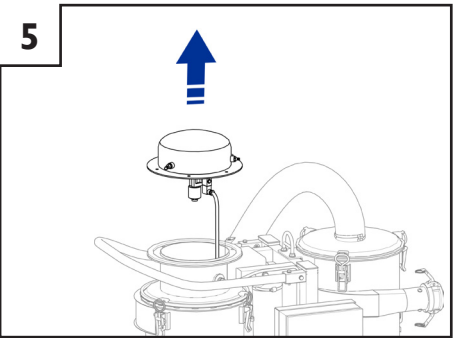
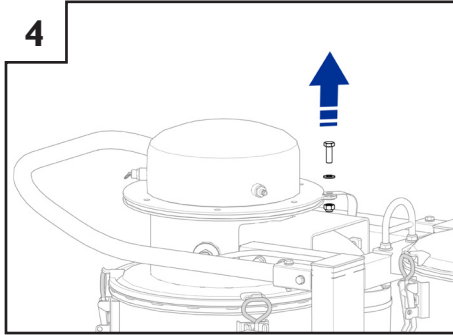
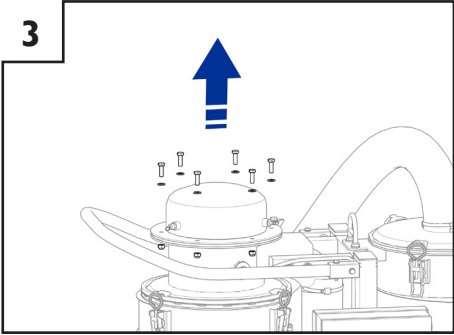
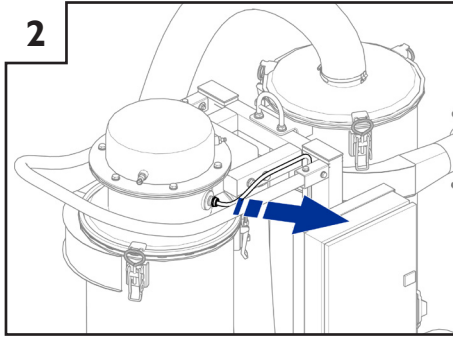
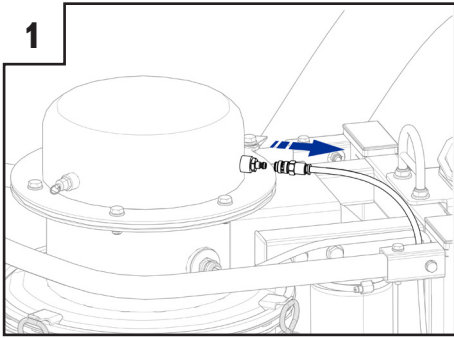

**Replace Filter Valve**



1. Remove the hose connection from the cap.
2. Unscrew the cable grommet.
3. Remove the 6 screws and washers from the plate.
4. Remove the screw and washer holding the ground cable.
5. Lift the top up.
6. Remove the cable.
7. Unscrew the valve and remove it.

Reverse steps for assembly.

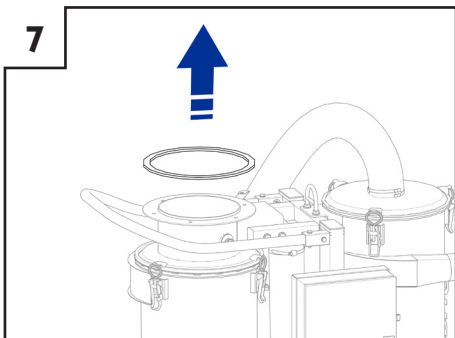
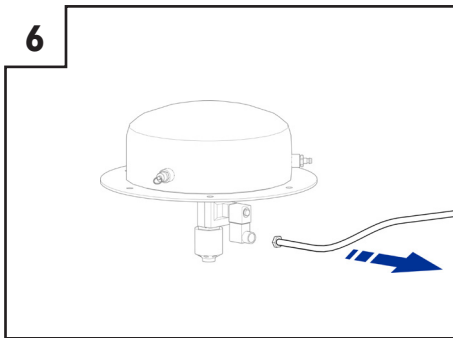
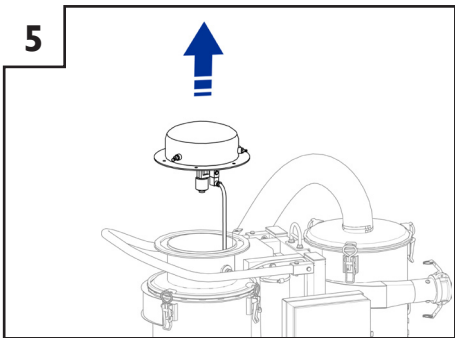
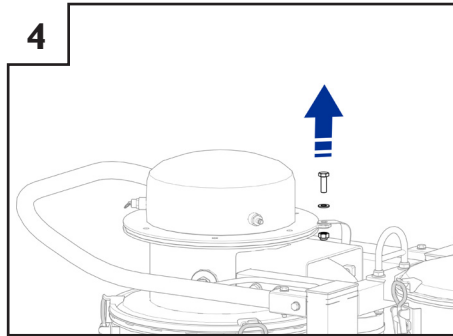
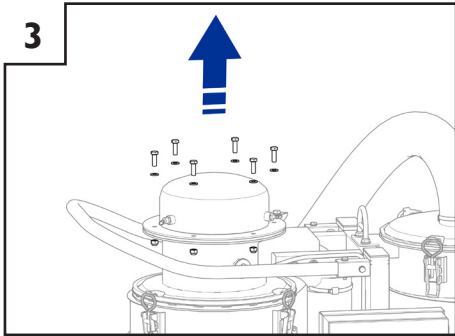
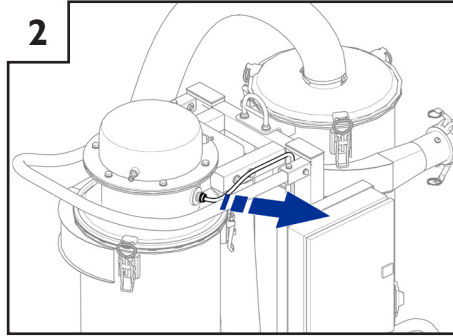
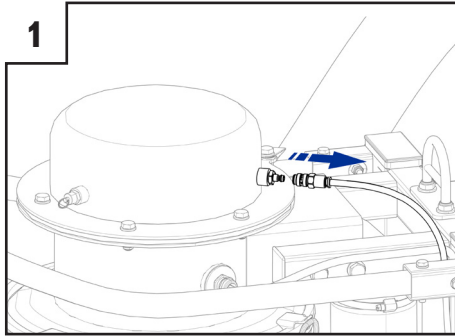

**Replace Filter Sealing**



1. Remove the hose connection from the cap.
2. Unscrew the cable grommet.
3. Remove the 6 screws and washers from the plate.
4. Remove the screw and washer holding the ground cable.
5. Lift the top up.
6. Remove the cable.
7. Remove the sealing and replace it with a new one.

Reverse steps for assembly.

## Controls CE

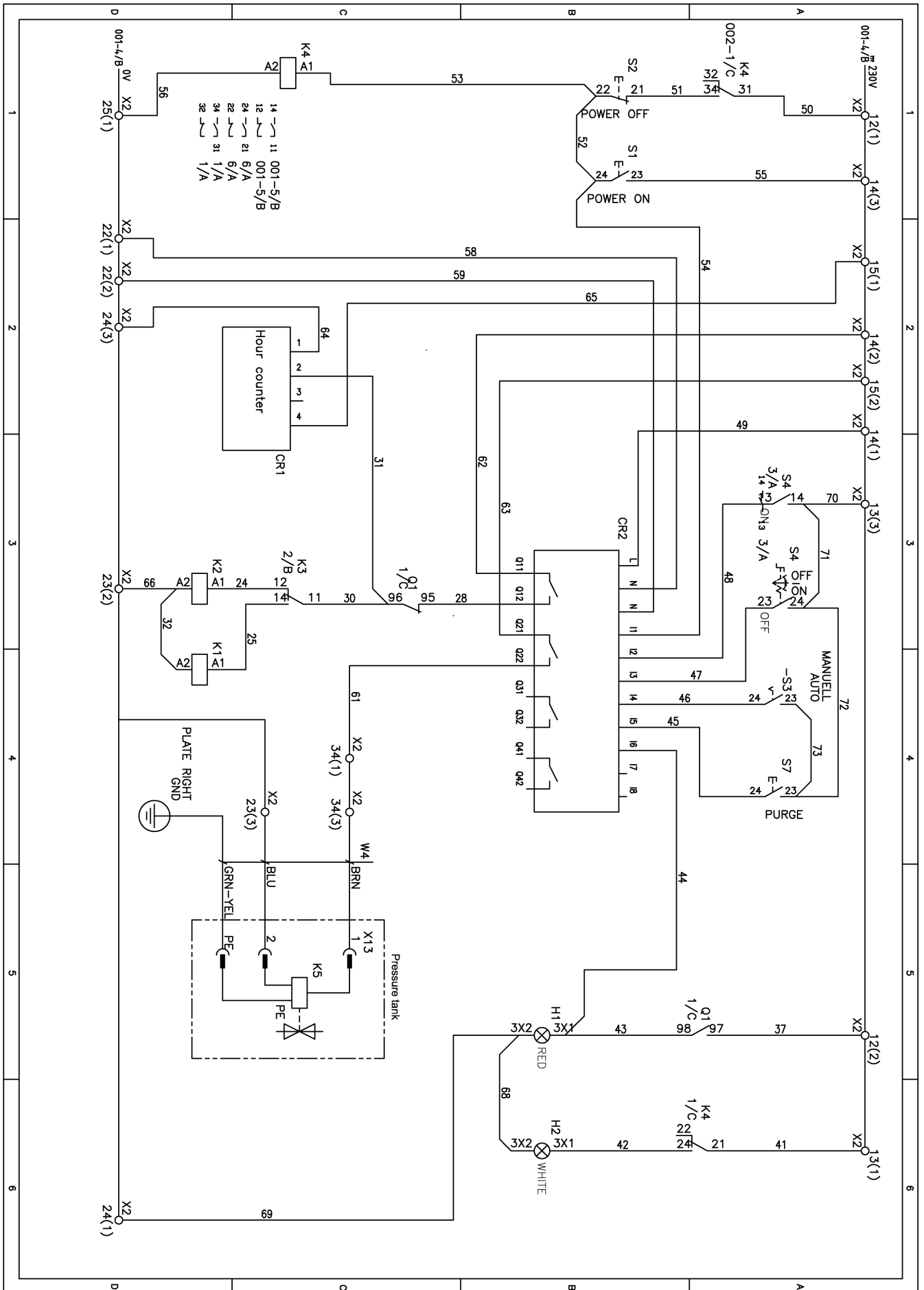

Controls US

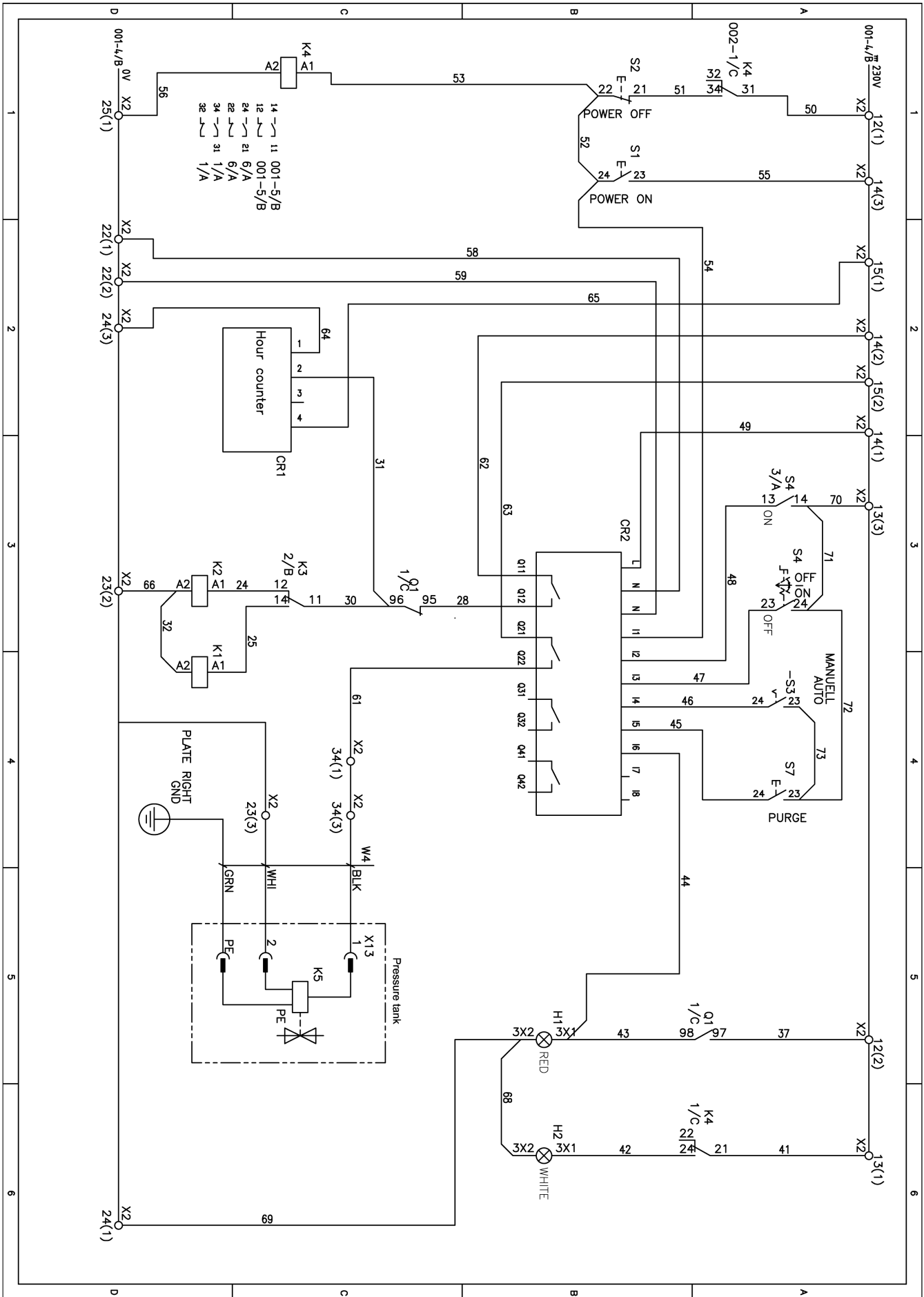

## Power CE

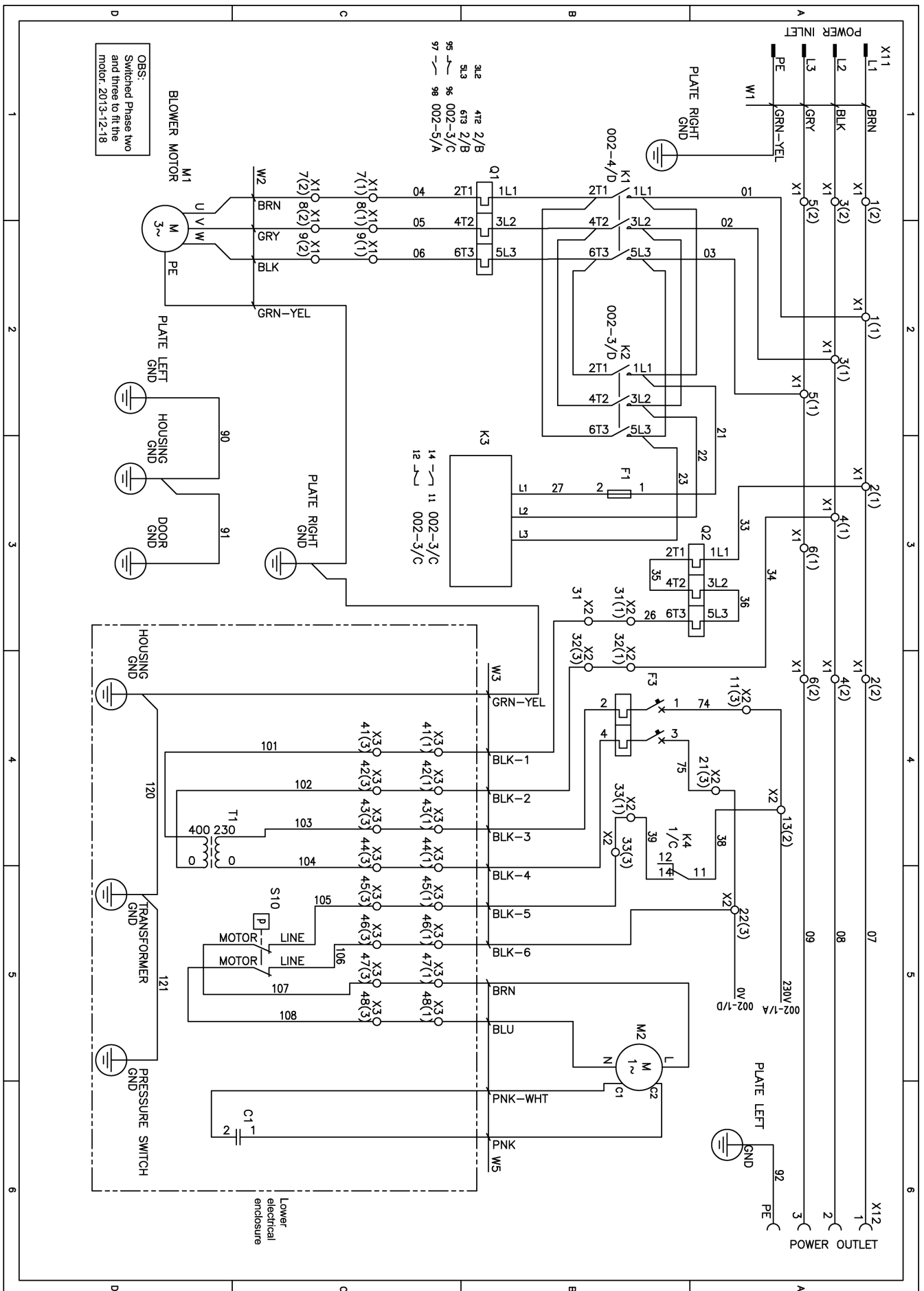

Power US

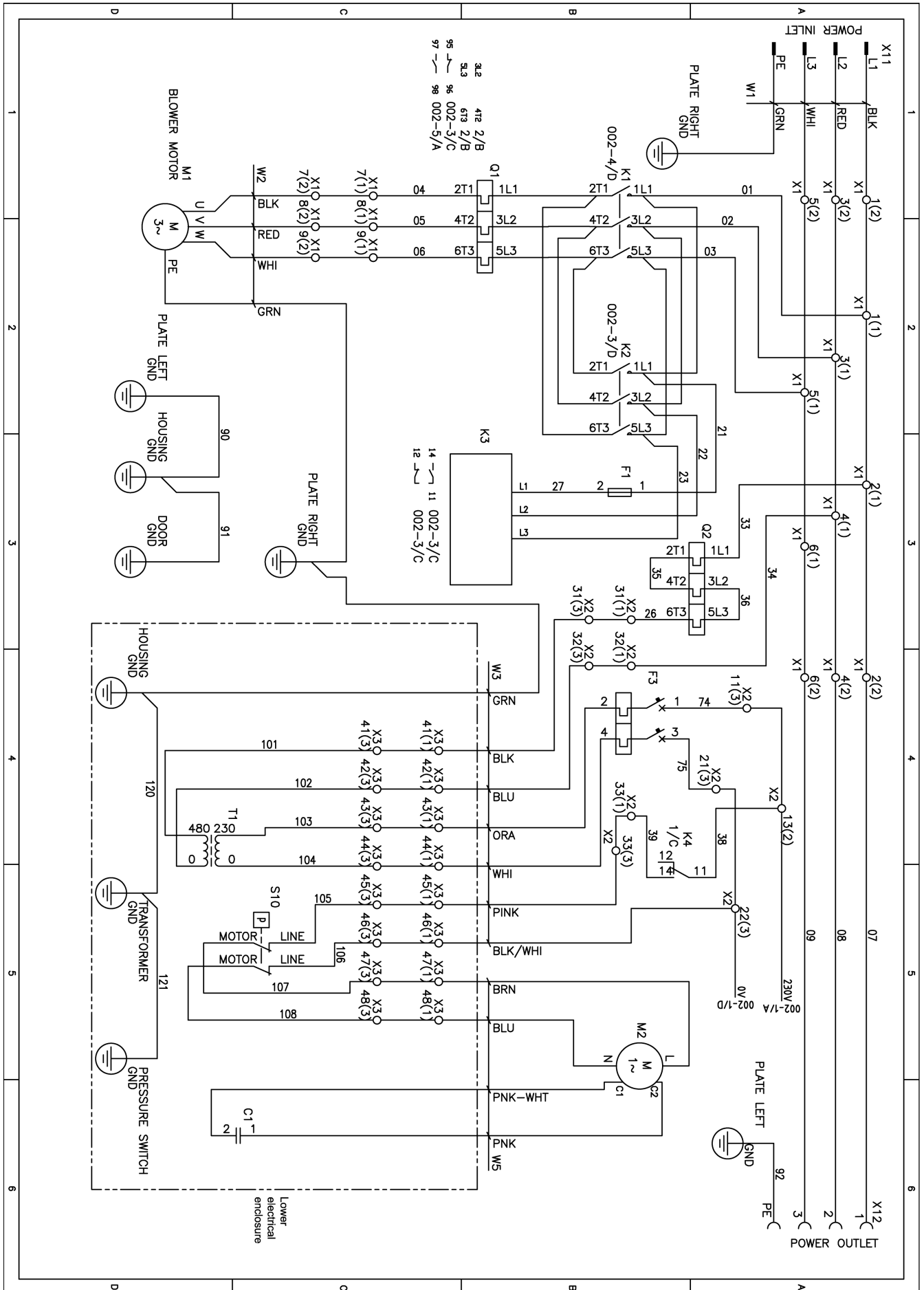



[www.husqvarnacp.com](http://www.husqvarnacp.com)

115 63 33-26

English